

Aesculap[®] Neuroendoscopy

Intraventricular, Endoscope-Assisted, Transnasal/Transsphenoidal Neuroendoscopic Equipment

With comments from international experts in the field of neuroendoscopy and minimally-invasive neurosurgery.



Aesculap Neurosurgery

Aesculap Neuroendoscopy

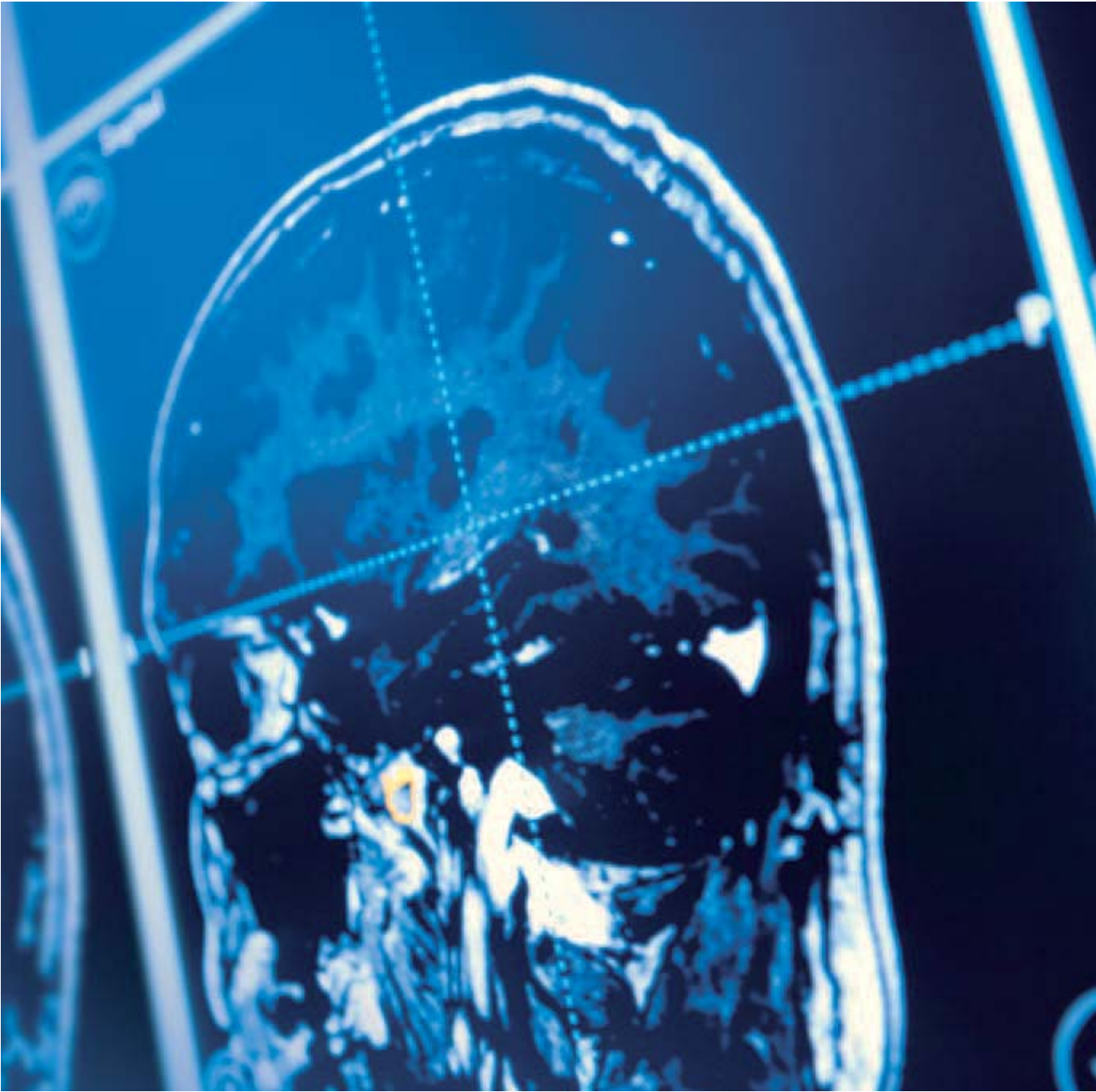

Michael Fritsch
Neubrandenburg, Germany



Jeremy Greenlee
Iowa City, USA



André Grotenhuis
Nijmegen, Netherlands



Nikolai Hopf
Stuttgart, Germany



“ In 1924, the famous general and neurological surgeon William Halsted expressed his belief “... that the tendency will always be in the direction of exercising greater care and refinement in operating”. Today, within the third millennium this fundamental philosophy of minimally invasive therapy should be emphasized more than ever before, operating with a minimum of iatrogenic trauma while achieving maximum surgical efficiency.

Recent improvements in preoperative imaging and surgical instrumentation allow neurosurgeons to treat more complex pathologies through customized less invasive approaches.

Using the advanced diagnostic tools of digital subtraction angiography, 3D angiography, computed tomography and magnetic resonance imaging, one is able to demonstrate and elucidate preoperatively the individual anatomy and pathology of the patient. Therefore, anatomically preformed surgical dissection can be described preoperatively and may so be included into the planning of surgery. With the individual anatomic details of a specific patient, it becomes possible to perform a tailored surgical procedure reducing the size of the skin incision, the craniotomy, and the extent of brain surface traumatization and retraction to a necessary minimum limit. These advantages of minimally invasive microsurgery contribute to improved postoperative results, including shorter hospitalization time because of reduction of the risk for complications.

However, small sized minimally invasive approaches cause two important limitations: the significant loss of optical control and limited maneuverability of microsurgical instruments. The intraoperative use of endoscopes and dedicated minimally invasive instruments overcome these restrictions, thus enabling neurosurgeons to

achieve deep seated regions without approach related traumatization of sensitive neurovascular structures.

The endoscopic image allows illumination and inspection of angles in hidden parts of the surgical field with the and clear depiction of anatomical details. In addition, due to the enormous optical depth of field of modern endoscopes, endoscopes provide a three dimensional aspect of anatomic structures. Recently, the intraoperative use of full high definition (HD) image quality offers a new area in endoscopic neurosurgery with an increased range of indications in minimally invasive neurosurgery.

There are three main indications of endoscopic neurosurgery: the intraventricular, transcranial and transnasal application. In this brochure, contemporary endoscopic equipment and instrumentation is presented in a comprehensive way. International experts in the field of minimally invasive and endoscopic neurosurgery comment the different applications, giving remarks with important tips and ideas, thus providing valuable instructions for the use of endoscopes in the field of minimally invasive neurosurgery.”

The Aesculap Advisory Board for “Minimally-Invasive Neurosurgery & Neuroendoscopy”

Michael Fritsch, Neubrandenburg, Germany
 Jeremy Greenlee, Iowa City, USA
 Andre Grotenhuis, Nijmegen, Netherlands
 Nikolai Hopf, Stuttgart, Germany
 Peter Nakaji, Phoenix, USA
 Robert Reisch, Zurich, Switzerland
 Mark Souweidane, New York, USA
 Charles Teo, Sydney, Australia



Peter Nakaji
Phoenix, USA



Robert Reisch
Zurich, Switzerland



Mark Souweidane
New York, USA



Charles Teo
Sydney, Australia

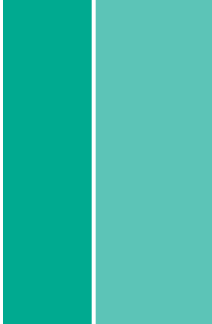

Intraventricular Neuroendoscopy



MINOP[®]

Intraventricular Neuroendoscopic System

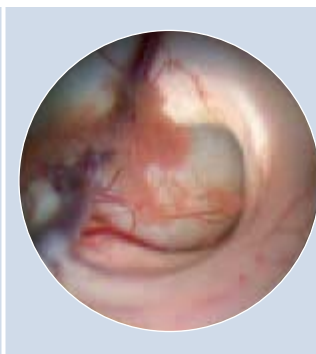



“ The genesis of endoscopic surgery within the ventricular compartment can be attributed to the development of small caliber rod lens optics, fiberoptic light transmission and dedicated instrumentation. Since the advent of intraventricular endoscopic surgery, neurosurgeons have applied the technology to treat a number of disorders. While the enthusiasm has been great and the full potential not yet realized, a major benefit to the patient has been proven for selected conditions. Most notably the treatment of non-communicating hydrocephalus, management of patients with pineal region tumors, fenestration of intracranial cysts, and removal of colloid cysts have all been shown to provide significant benefit and reduced morbidity compared with conventional treatment strategies.

The benefit in minimally invasive endoscopic procedures is analogous to that of any endoscopic procedure, namely minimal tissue disruption, enhanced visualization, improved cosmetic results, shorter hospital stay, and less surgical morbidity. The surgeon willing to utilize intraventricular endoscopic surgery is first responsible for attaining a considerable degree of familiarity with the technology, relevant anatomy, and the surgical procedures. Given the relative nascence of the field, the discipline is only now being commonly implemented in training programs. Hence, for those that have not had the opportunity to have endoscopic surgery as part of their formal training, it is strongly recommended that the surgeon participates in established practical courses in endoscopic neurosurgery, such as the courses from the Aesculap Academy.

Once fluent with the endoscopic equipment, more advanced procedures can be performed with greater familiarity and experience. It is anticipated with future generations of neurosurgeons that the endoscope will be an indispensable part of the neurosurgeon's armamentarium given the unmatched image resolution and minimally invasive qualities.

This foreseeable integration will expectantly be paralleled with continued evolution in compatible equipment to suit the needs of an expanding repertoire.

Few neurosurgical procedures demand a degree of familiarity with equipment as do neuroendoscopic techniques. This feature is somewhat explained by the recent introduction of the neuroendoscope as well as the delicate nature of the equipment. The basic components of any neuroendoscopic procedure include the endoscope and trocar, a camera with light source and monitor, as well as compatible instrumentation. ”

Charles Teo
Mark Souweidane



Charles Teo
Sydney, Australia



Mark Souweidane
New York, USA

MINOP®

Intraventricular Neuroendoscopic System

MINOP® Trocars

- Smooth tip of trocar for atraumatic insertion into the brain
- Single obturator for working channel enables insertion of the trocar, under visual control, with the scope
- Large MM-length inscription on the outer shaft of the trocar
- Conical entry of working channel for intuitive insertion of instruments into trocar
- Attachment on top of trocar for improved handling and universal connection of peripheral devices



FF399R

MINOP® trocar,
Outer diameter 6 mm

4 channels:

Scope channel, diam. 2.8 mm

Working channel, diam. 2.2 mm

Irrigation channel, diam. 1.4 mm

Overflow channel, diam. 1.4 mm

Including 4 obturators
for all channels

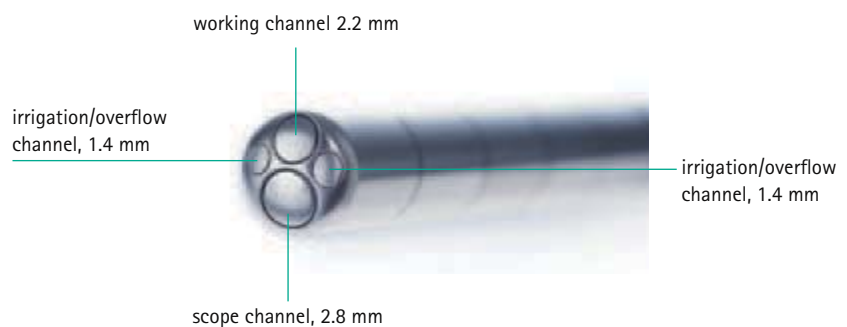

“ I had used the Aesculap MINOP system for all intraventricular cases and was mostly pleased with its versatility and safety. However, I had some concerns regarding its user-friendliness and applicability when one needed to be a 2-handed surgeon. Both these issues have been addressed with the new, improved MINOP trocar and I have been very pleased with its added safety and practicality. I honestly believe it is quite clearly the best scope on the market for intraventricular endoscopic procedures. I applaud Aesculap for listening to the people who count most... the surgeons! ”

Charles Teo, Sydney, Australia



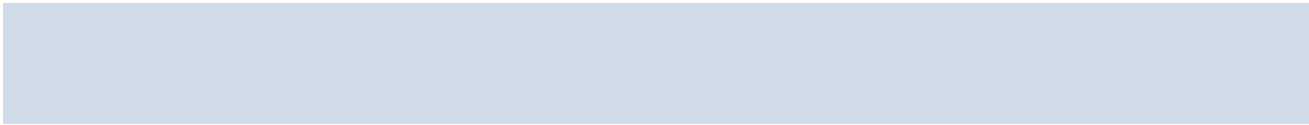

FF398R

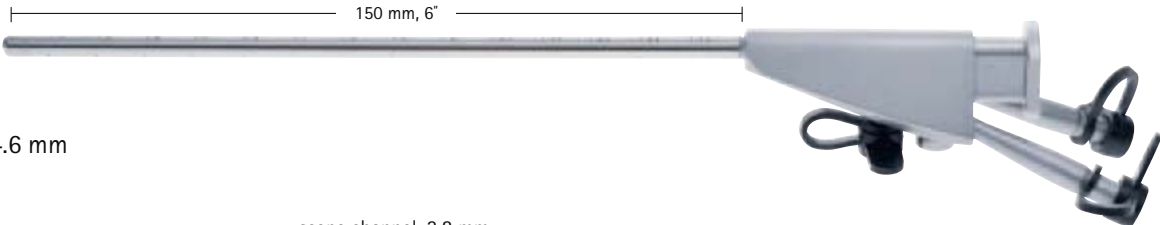

MINOP® trocar,
Outer diameter 4.6 mm

3 channels:

- Scope channel, diam. 2.8 mm
- Irrigation channel, diam. 0.8 mm
- Overflow channel, diam. 0.8 mm
- Including one obturator for scope channel
- One sealing cap for pressure balance in scope channel

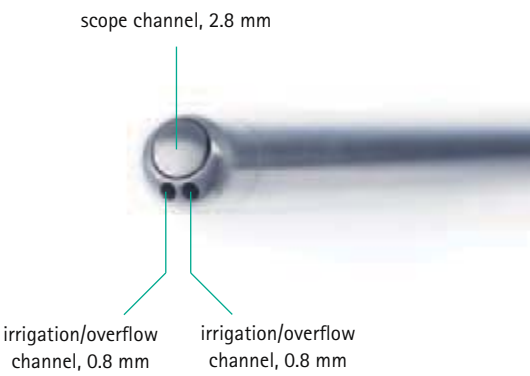

FF397R



MINOP® trocar,
Outer diameter 3.2 mm

1 channel:

- Single channel for scope
- Including one obturator
- Scope channel, diam. 2.8 mm
- One sealing cap for pressure balance in scope channel

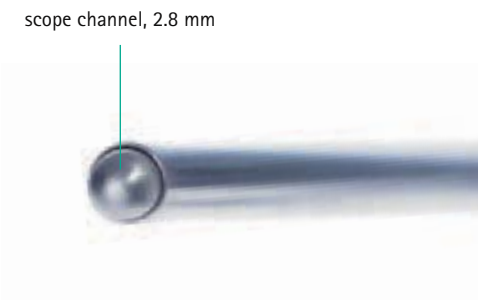

MINOP®

Intraventricular Neuroendoscopic System

MINOP® Endoscopes

- FULL HD compatible
- New optical components for enlarged image area and enhanced image quality, brightness, contrast
- Improved fibre optics provide more light
- The external tube is made from a high strength special alloy for superior breaking resistance
- Service-optimised construction reduces maintenance costs
- Autoclavable/Steris/Sterrad

PE184A

MINOP® endoscope

Direction of view 0°
(green ring)

Shaft diameter, 2.7 mm

Shaft length, 180 mm

Autoclavable

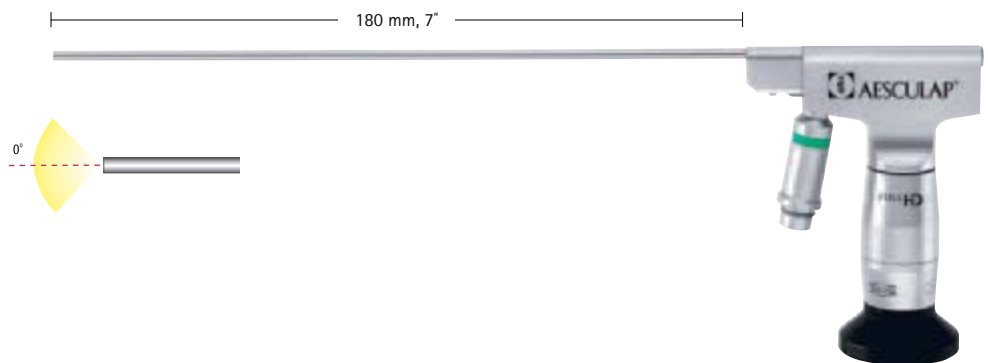

PE204A

MINOP® endoscope

Direction of view 30°,
upwards (red ring)

Shaft diameter 2.7 mm

Shaft length 180 mm

Autoclavable

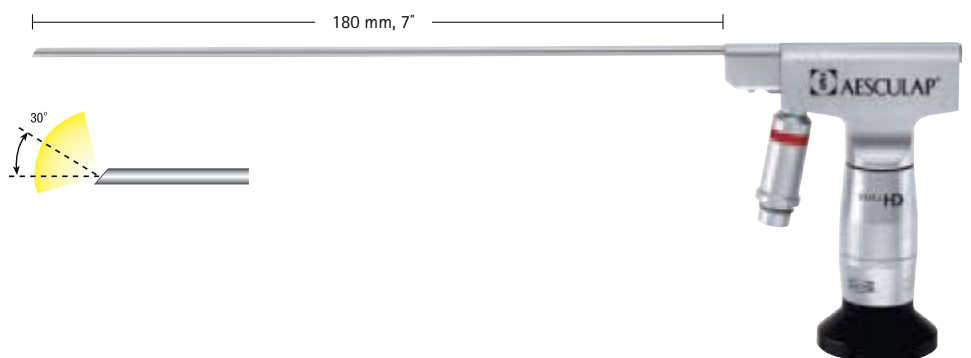

“The angled design of the MINOP ventricular endoscope plays a central role in ergonomic and effective application, allowing the use of rigid instruments through the straight working channel. In this way, the side-gated camera and light cable do not disturb surgical manipulation. In my hands, an undisputable advantage!”

Robert Reisch, Zurich, Switzerland



MINOP® Rigid Instruments

Instruments

- Shaft length 265 mm
- Diam. 2.0 mm
- Fully detachable for reprocessing
- High precision instrument tip

Tactile Feedback

- Integrated tactile feedback delivers small resistance indicating that instrument tip emerges from the trocar
- Improves control during insertion of instruments

Rotating Knob

- By rotating the knob slightly with index finger, the tip of instrument turns equally
- No need anymore to turn/rotate instrument with the entire arm/handle
- Improves precision of neuro-endoscopic surgery
- Integrated safety mechanism in instrument shaft

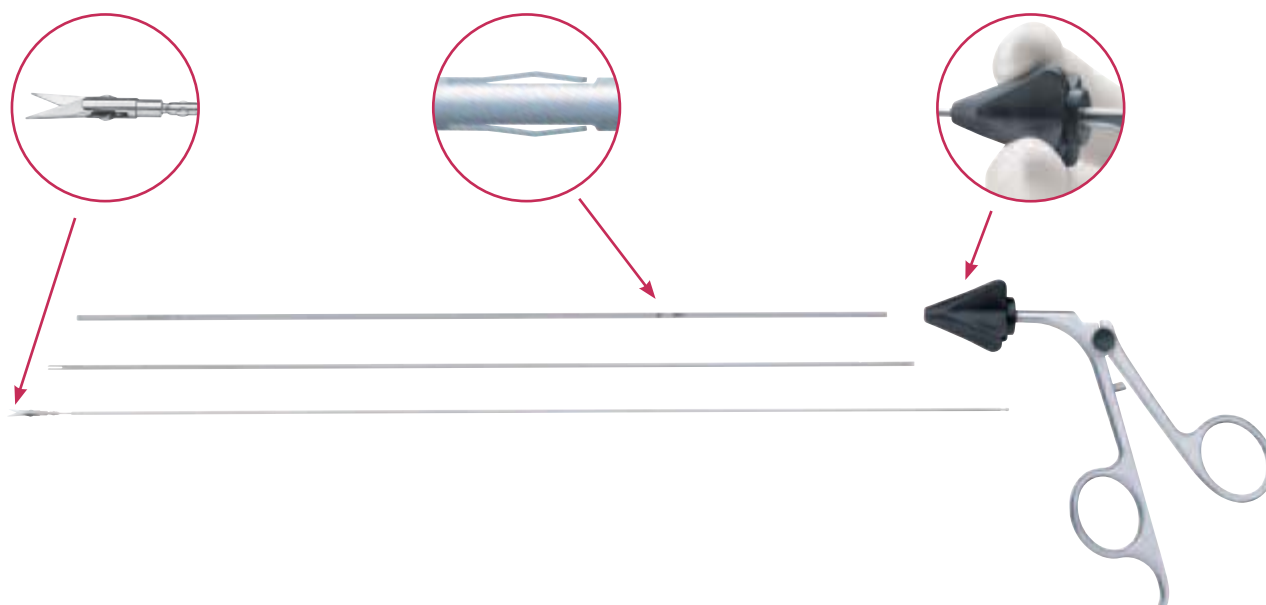

“ A very appealing feature of the MINOP tube shaft instruments is a rotational capability of the instrument tip through a coaxial system thus eliminating the need for hand rotation and reducing excessive movement of the endoscope. Irrespective of the instrument, graduated markings or precalibrated indicators on the shaft are important in providing the surgeon knowledge as to when the instrument will enter the endoscopic field. Even more safety is provided by the new tactile feedback of the improved MINOP instruments. A small spring delivers a tactile resistance “telling” the surgeon that the instrument tip is exiting the trocar. ”

Mark Souweidane, New York, USA

MINOP®

Intraventricular Neuroendoscopic System

MINOP® Rigid Instruments

Ø 2 mm Instrument complete: Handle · outer tube · jaw part with inner tube

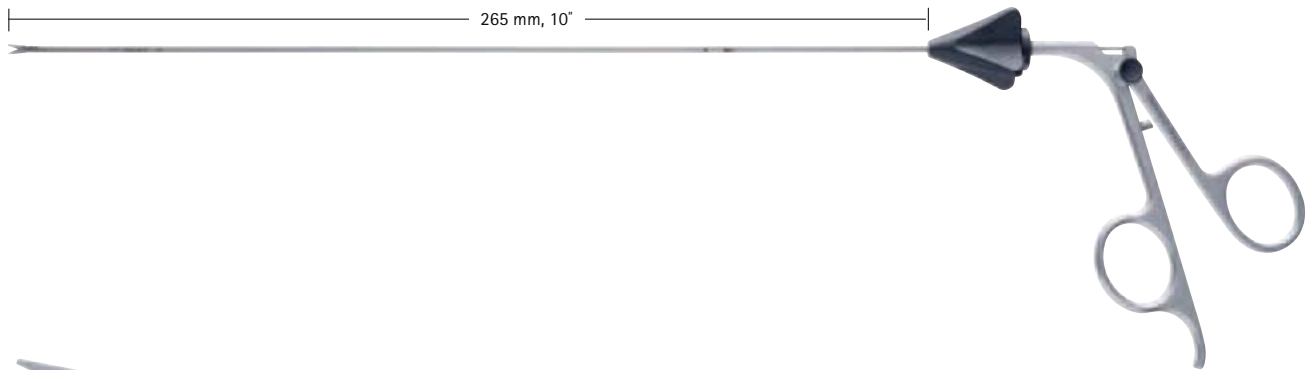

FF385R

MINOP® scissors
sharp/sharp



FF386R

MINOP® scissors
blunt/blunt



FF388R

MINOP® grasping and dissecting forceps



FF387R

MINOP® biopsy forceps



FF389R

MINOP® surgical forceps

The very delicate MINOP® instruments should be carefully detached completely and be pre-cleaned manually at the end of the operation. Keeping them in dedicated trays for reprocessing and sterilization protects the super-fine instrument tips. A careful handling by trained operating & CSSD staff is highly recommended and can eliminate the wear and tear of these sensitive but highly necessary neuroendoscopic tools.

MINOP® Rigid Instruments – Spare Parts

∅ 2 mm Jaw part with inner tube for FF385R - FF389R

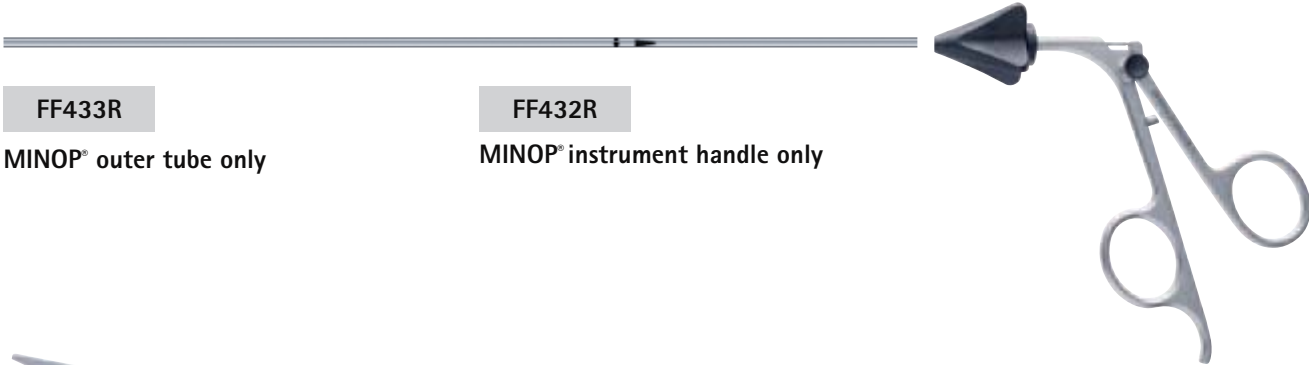

FF433R
MINOP® outer tube only

FF432R
MINOP® instrument handle only



FF435R
MINOP® scissors, jaw part
sharp/sharp



FF436R
MINOP® scissors, jaw part
blunt/blunt



FF438R
MINOP® grasping and dissecting forceps, jaw part



FF437R
MINOP® biopsy forceps, jaw part



FF439R
MINOP® surgical forceps, jaw part



For disassembly and assembly of MINOP® tube shaft instruments, please ask your local Aesculap sales representative: Brochure C60902 (English), C60901 (German).

MINOP®

Intraventricular Neuroendoscopic System

MINOP® – Flexible Instruments

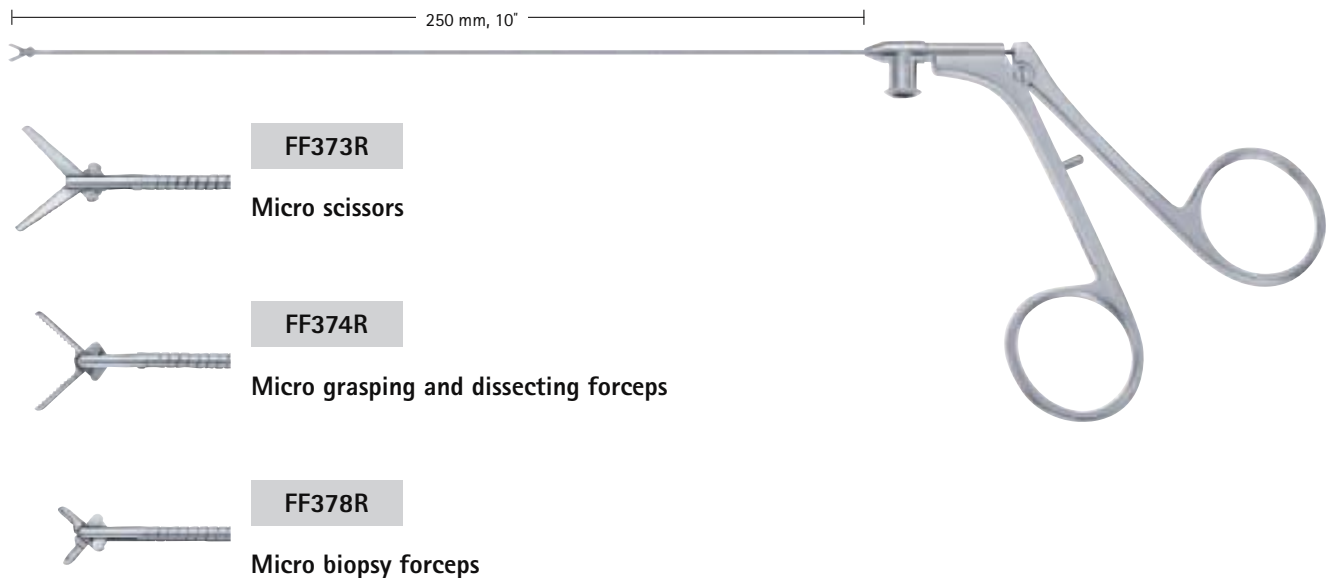

Ø 1 mm 1.0 mm Instruments for bi-instrumental work



Flexible instruments:

- For bi-instrumental / bi-manual neuroendoscopic surgery
- E.g. grasping and cutting, grasping and coagulating, grasping and fenestrating
- To be used through irrigation or overflow channel of the MINOP® trocar FF399R
- Diam. 1.0 mm, shaft length 250 mm
- Non-detachable
- With irrigation port for reprocessing/cleaning

“ The MINOP® system is providing bi-instrumental endoscopic work. For example in cyst removal or endoscopic tumor surgery the surgeon has the opportunity to grasp and cut or grasp and coagulate at the same time. One can utilize flexible instruments or electrodes in one of the side-channels and rigid tube shaft instruments in the working channel. The design of the side-channels of the MINOP® trocar makes sure that both instruments do not interfere with each other.”

Michael Fritsch, Neubrandenburg, Germany



MINOP® – Electrodes

MONOPOLAR ELECTRODES

- GK361R**

1:1

255 mm, 10"



Blunt electrode, diam. 1.1 mm
- GK363R**

1:1



Needle electrode, diam. 1.1 mm
- GK364R**

1:1



Hook electrode, 45°, diam. 2.2 mm
- GK365R**

1:1



Hook electrode, 70°, diam. 2.2 mm
- GK362R**

1:1



Hook electrode, 90°, diam. 2.2 mm
- GK366R**

1:1



Hook electrode, 180°, diam. 2.2 mm

GN202  4 mm Socket
 Monopolar cable
 suitable for GN300, GN640, 3.5 m

BIPOLAR ELECTRODE

GK360R  255 mm, 10"
 Fork electrode, diam. 2.1 mm

GN130 
 Bipolar cable
 suitable for GN060, GN160, GN300, GN640, length 4 m



MINOP®

Intraventricular Neuroendoscopic System

MINOP® – Suction Cannula

MINOP® Disposable Suction Cannula

- For removal of cystic intraventricular lesions
- For puncturing the floor of the 3rd ventricle
- With depth marking, interval of 5 mm
- Outer diameter of 2.0 mm
- Suitable for working channel of MINOP® trocar FF399R
- Available with blunt or sharp tip suction cannula
- Optional control of suction
 - via thumb plate or
 - via syringe
- Single-use, sterile packaging

FH606SU

Suction cannula,
blunt tip 0°,
diam. 2.0 mm

FH607SU

Suction cannula,
sharp tip 45°,
diam. 2.0 mm



MINOP® – Disposable Introducer

MINOP® Disposable Introducer

- 19 Fr disposable introducer set including obturator and sheath
- Especially for MINOP® trocar FF399R
- Introducer sheath protects the brain while inserting and removing the endoscope/trocar
- Round & blunt obturator tip for atraumatic insertion into the ventricles
- Depth scale for precise positioning and perfect control
- Easy to peel with side handles

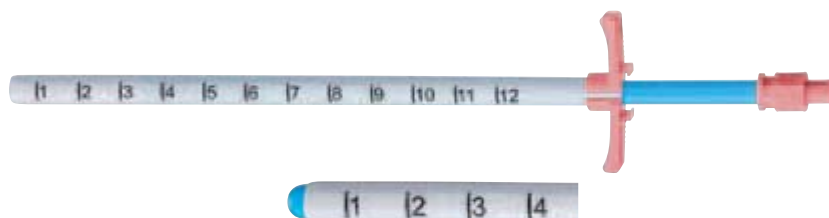

FH604SU

Introducer,
19 Fr



The MINOP® suction cannula and the MINOP® disposable introducer can be used in almost any intraventricular neuroendoscopic surgery providing more control during the procedure. The suction cannula can be used for the controlled and fast removal of intraventricular soft tumors or colloid cysts with its sharp cannula tip or even for the opening of the floor of the 3rd ventricle. The disposable introducer (also called peel away) is very helpful when several intraparenchymal in- and out-movements of the trocar are necessary.

MINOP®

Intraventricular Neuroendoscopic System

MINOP® – Storage

FF358R

For MINOP® trocars and scopes

Storage rack with silicone protection cushioning

Bottom and lid

Only for reprocessing, not for transportation/shipment

(L/W/H 489 x 257 x 63 mm)



FF359R

For MINOP® instruments and electrodes

Storage rack with silicone protection cushioning

Bottom only, lid not necessary

Only for reprocessing, not for transportation/shipment

(L/W/H 485 x 253 x 120 mm)

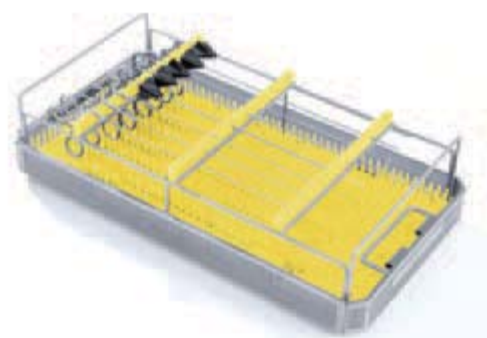

JK440

Container body 1/1

for FF358R

without base perforation

Outside/Inside dimensions with lid:

L/W/H 592 x 285 x 112 mm

L/W/H 544 x 258 x 75 mm

JK444

Container body 1/1

for FF359R

without base perforation

Outside/Inside dimensions with lid:

L/W/H 592 x 285 x 209 mm

L/W/H 544 x 258 x 172 mm

JK486

Container lid 1/1

blue



Dedicated storage racks for cleaning and reprocessing are highly recommended for your neuroendoscopic equipment. A special-designed storage concept is keeping the scopes and instruments properly stored and protected.

PF893800

Cleaning brush



EJ751251

Sealing cap Luer-Lock

20 pcs. per pack



EJ751200

Sealing cap

1 pc. per pack



For more information about sterile container systems and accessories, please ask your local Aesculap sales representative: Brochure C40402 (English), C40401 (German).



Paediscopes

Paediatric Intraventricular Neuroendoscopic System

Paediscopes

PF010A

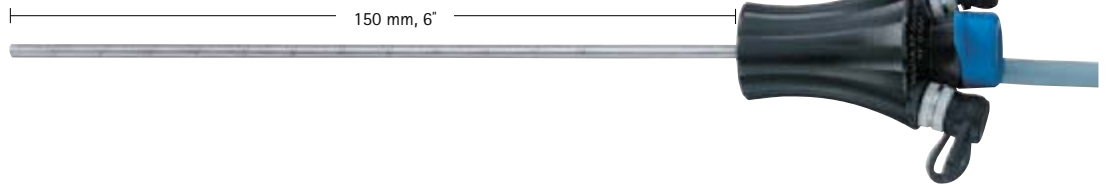

PF011A

Ocular with focus

* for complete Paediscopes,
please order both PF010A
and PF011A



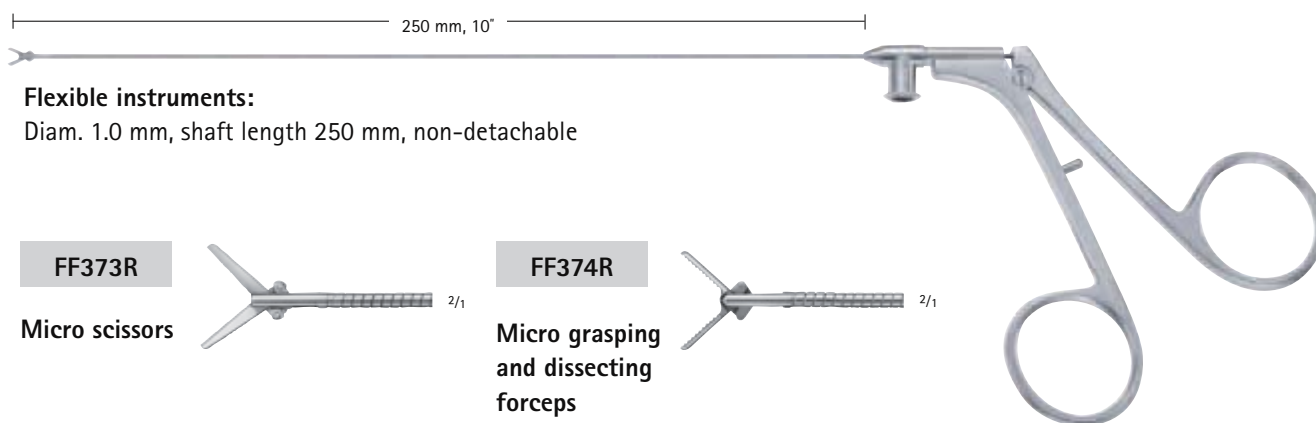

Flexible instruments:

Diam. 1.0 mm, shaft length 250 mm, non-detachable



FF373R
Micro scissors

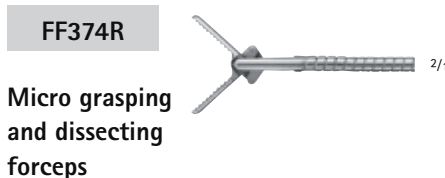

FF374R
Micro grasping and dissecting forceps



FF378R
Micro biopsy forceps

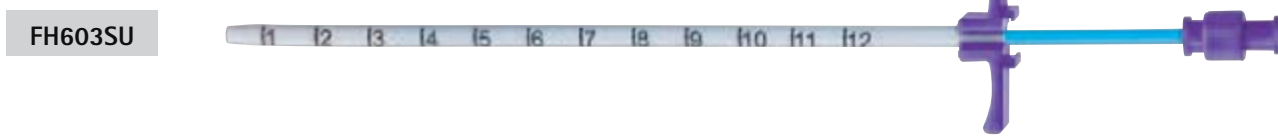

FH603SU

- Round & blunt obturator tip for atraumatic insertion into the ventricles
- Depth scale for precise positioning and perfect control
- Easy to peel with side handles



“ The peel away sheath protects the brain while inserting and removing the pediatric endoscope. Because of its small outer diameter, the Paediscopie does not have a dedicated trocar. The blunt obturator tip of the sheath allows atraumatic insertion into the ventricles. The sheath has a depth scale for precise positioning and is easy to peel back the side handles. Using a peel away sheath is especially helpful, if repeated in and out movements of the scope are necessary or different instruments or catheters (e.g. for aqueductoplasty) have to be utilized in addition to the scope. ”

Michael Fritsch, Neubrandenburg, Germany

Paediscopes

Paediatric Intraventricular Neuroendoscopic System

Paediscopes

GK363R

Needle electrode,
diam. 1.1 mm

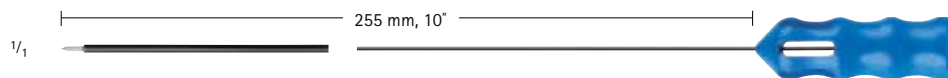

GK361R

Blunt electrode,
diam. 1.1 mm



GN202

Monopolar cable
suitable for GN300, GN640, 3.5 m



FF379R

For Paediscopes shaft,
instruments and electrodes

Storage rack with silicone
protection cushioning

Bottom and lid

Only for reprocessing, not
for transportation/shipment

(L/W/H 489 x 257 x 63 mm)

**JK440****Container basis 1/1**

for FF379R

without base perforation

Outside/Inside dimensions with lid:

L/W/H 592 x 285 x 112 mm

L/W/H 544 x 258 x 75 mm

**JK486****Container basis 1/1 lid**

blue

For more information about MINOP®
please see our „Practical Atlas“ C29202.



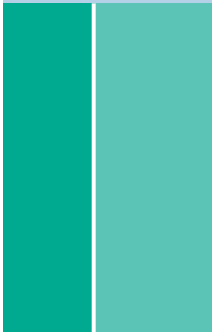

Advanced Intraventricular Neuroendoscopy



MINOP[®] InVent

Advanced Intraventricular Endoscopic System

MINOP[®] InVent – Trocars

- Intraventricular system for experienced neuroendoscopic surgeons
- New trocar concept reduces brain trauma
- Oval working channel allows "microsurgical" techniques
- Enables the use of instruments with angled tips
- Wide range of up to 32 instruments available
- Connection for holding arm and intraoperative imaging

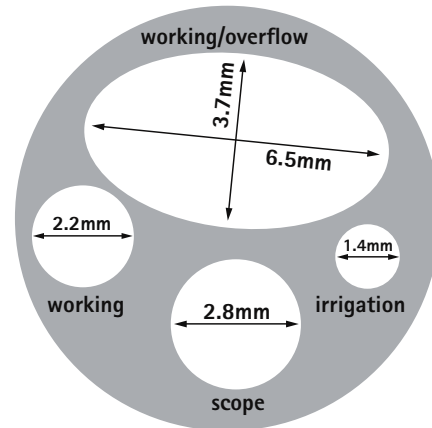

FH620R

MINOP[®] InVent trocar
Outer diameter 8.3 mm

3 (4) channels:

Scope channel, diam. 2.8 mm

Irrigation channel, diam. 1.4 mm

Two merging channels:

Large working/overflow channel:
3.7 mm x 6.5 mm

Small working channel: diam. 2.2 mm

Including 2 obturators for scope channel
and large working/overflow channel

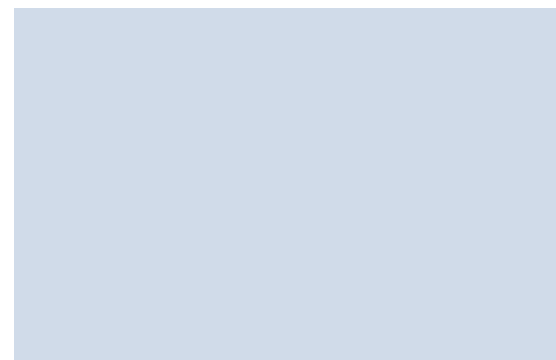
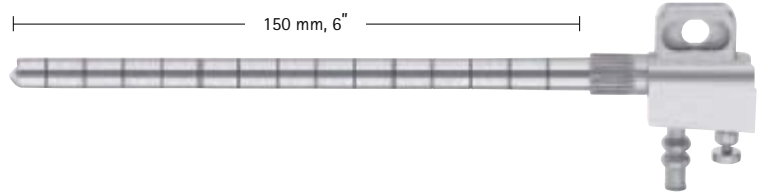

MINOP[®] InVent – Endoscope

- FULL HD compatible
- New optical components for enlarged image area and enhanced image quality, brightness, contrast
- Improved fibre optics provide more light
- The external tube is made from a high strength special alloy for superior breaking resistance
- Service-optimised construction reduces maintenance costs
- Autoclavable/Steris/Sterrad

PE204A

MINOP[®] endoscope

Direction of view 30°, upwards (red ring)

Shaft diameter 2.7 mm

Shaft length 180 mm

Autoclavable

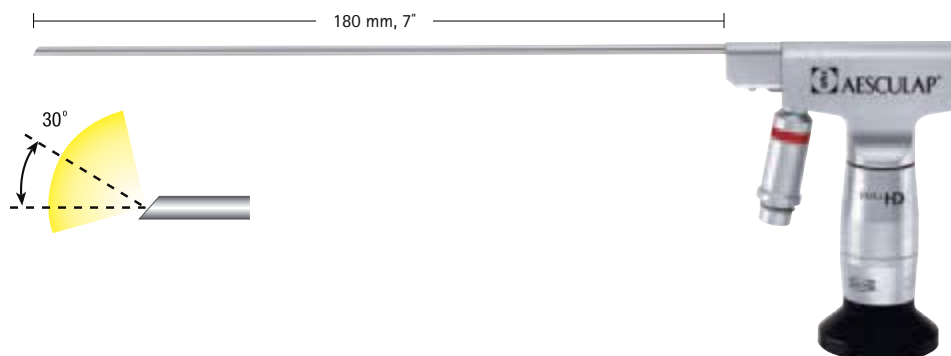

“ The MINOP InVent system is truly unique and the next step for the future of Neuroendoscopy. This system allows for a true bi-manual technique through the large/small working channels expanding the possibilities to treat further indications. The angled instrumentation provide the ability to simultaneously grasp and cut or grasp and coagulate similar to traditional microsurgery. The MINOP InVent provides a new possibility for the treatment of intra- and paraventricular cysts and tumors in complex hydrocephalus and alleviating the need for certain craniotomies. ”

Mark Souweidane, New York, USA

MINOP® InVent

Advanced Intraventricular Endoscopic System

MINOP® InVent – Dissectors, Hooks and Knives

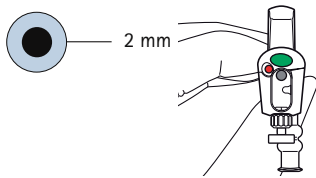

FH629R

MINOP® InVent dissector,
tip width 2.2 mm



FH632R

MINOP® InVent hook 90° blunt,
hook deflection width 3.5 mm



FH630R

MINOP® InVent dissector,
tip width 1.7 mm



FH634R

MINOP® InVent knife, backwards cutting,
knife deflection width 3.0 mm



FH631R

MINOP® InVent dissector,
tip width 1.0 mm



MINOP® InVent - Shaft Instruments

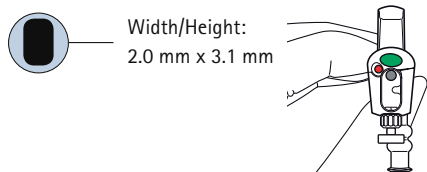

290 mm, 11½"



FH621R

MINOP® InVent forceps straight



FH625R

MINOP® InVent scissors straight



FH622R

MINOP® InVent forceps right



FH626R

MINOP® InVent scissors left



FH623R

MINOP® InVent forceps left



FH627R

MINOP® InVent scissors right



FH624R

MINOP® InVent grasping forceps straight



FH628R

MINOP® InVent scissors upwards



MINOP® InVent

Advanced Intraventricular Endoscopic System

MINOP® InVent – Tube Shaft Instruments | Complete Instruments

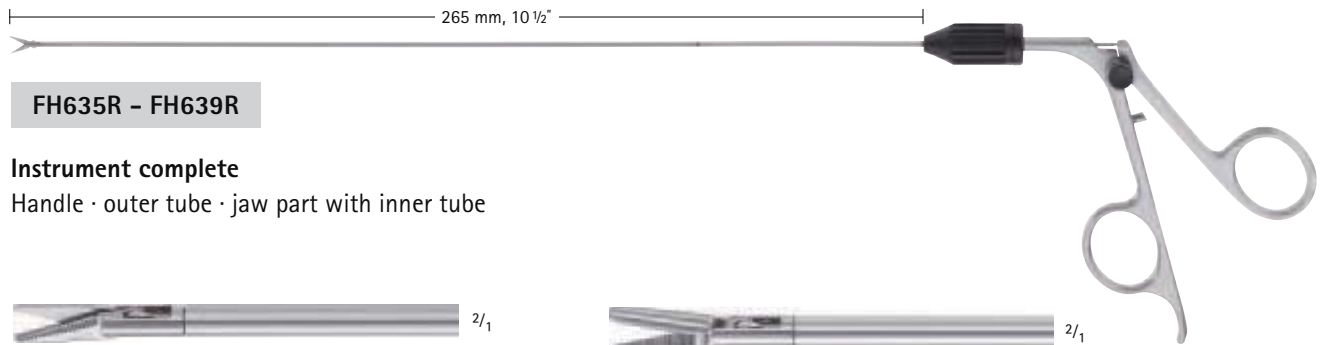
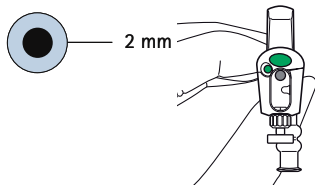

FH635R - FH639R

Instrument complete

Handle · outer tube · jaw part with inner tube



FH635R

MINOP® InVent scissors
sharp/sharp



FH638R

MINOP® InVent grasping and dissecting forceps



FH636R

MINOP® InVent scissors
blunt/blunt



FH639R

MINOP® InVent surgical forceps



FH637R

MINOP® InVent biopsy forceps



MINOP® InVent - Tube Shaft Instruments | Spare Parts

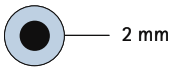

FH635200

MINOP® InVent outer tube only

FH633R

MINOP® InVent instrument handle only



FF435R

MINOP® InVent scissors, jaw part sharp/sharp



FF438R

MINOP® InVent grasping and dissecting forceps, jaw part



FF436R

MINOP® InVent scissors, jaw part blunt/blunt



FF439R

MINOP® InVent surgical forceps, jaw part



FF437R

MINOP® InVent biopsy forceps, jaw part



For disassembly and assembly of MINOP® tube shaft instruments, please ask your local Aesculap sales representative: Brochure C60902 (English), C60901 (German).

MINOP® InVent

Advanced Intraventricular Endoscopic System

MINOP® InVent – Bipolar Electrodes

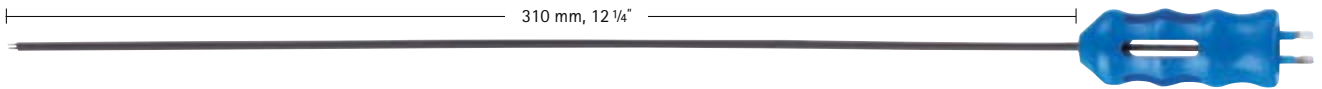
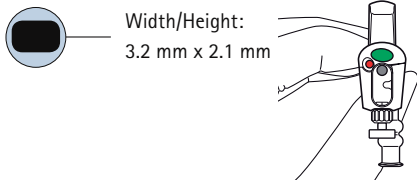

GK343R

**MINOP® InVent
bipolar electrode 0°**



GK344R

**MINOP® InVent
bipolar electrode 40°**



GK345R

**MINOP® InVent
bipolar electrode 30°**

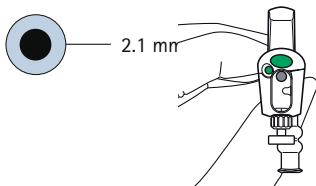

GK360R

Bipolar fork electrode 0°

GN130

Bipolar cable
suitable for GN060, GN160, GN300,
GN640, length 4 m

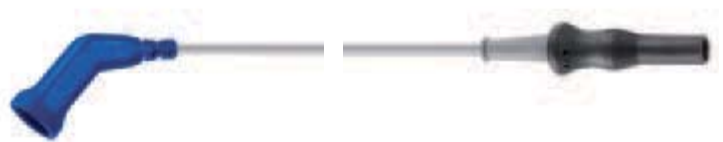

MINOP® InVent - Monopolar Electrodes

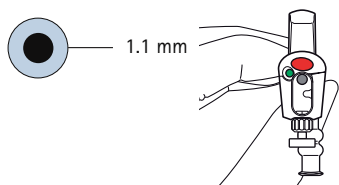

GK361R ^{2/1}
Blunt electrode, diam. 1.1 mm



GK363R ^{2/1}
Needle electrode, diam. 1.1 mm



GK365R ^{2/1}
Hook electrode, 70°, diam. 2.2 mm



GK362R ^{2/1}
Hook electrode, 90°, diam. 2.2 mm



GK366R ^{2/1}
Hook electrode, 180°, diam. 2.2 mm



GK364R ^{2/1}
Hook electrode, 45°, diam. 2.2 mm

GN202

Monopolar cable
suitable for GN300, GN640, 3.5 m



MINOP® InVent

Advanced Intraventricular Endoscopic System

MINOP® InVent - Flexible Instruments & Suction Cannula

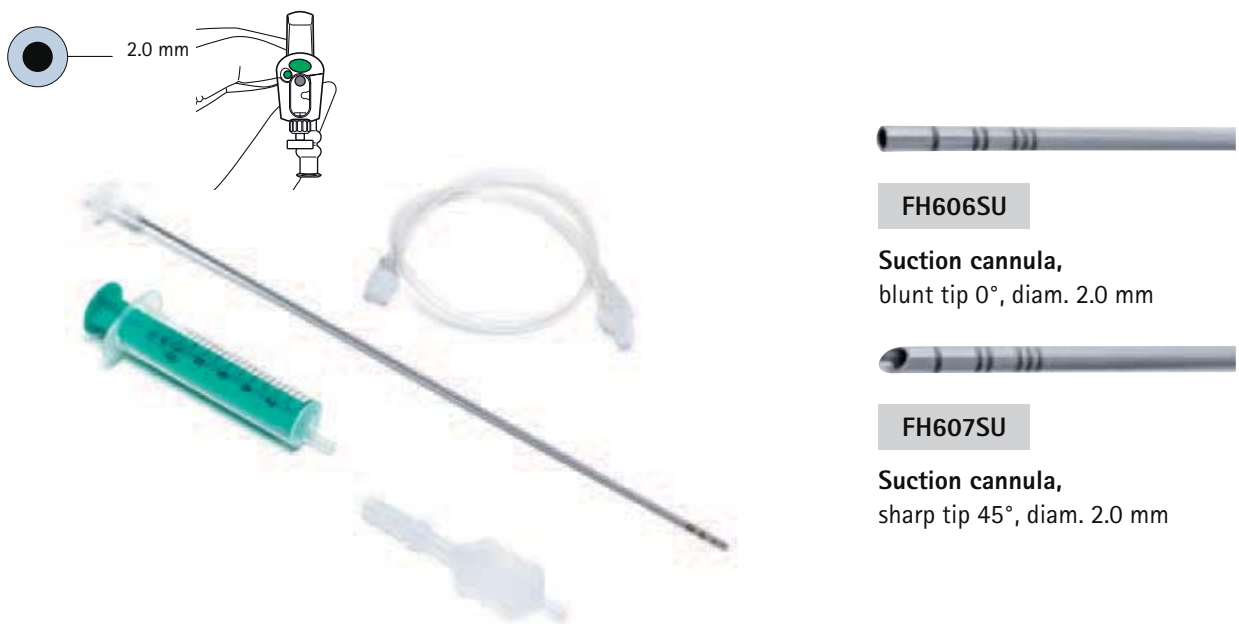
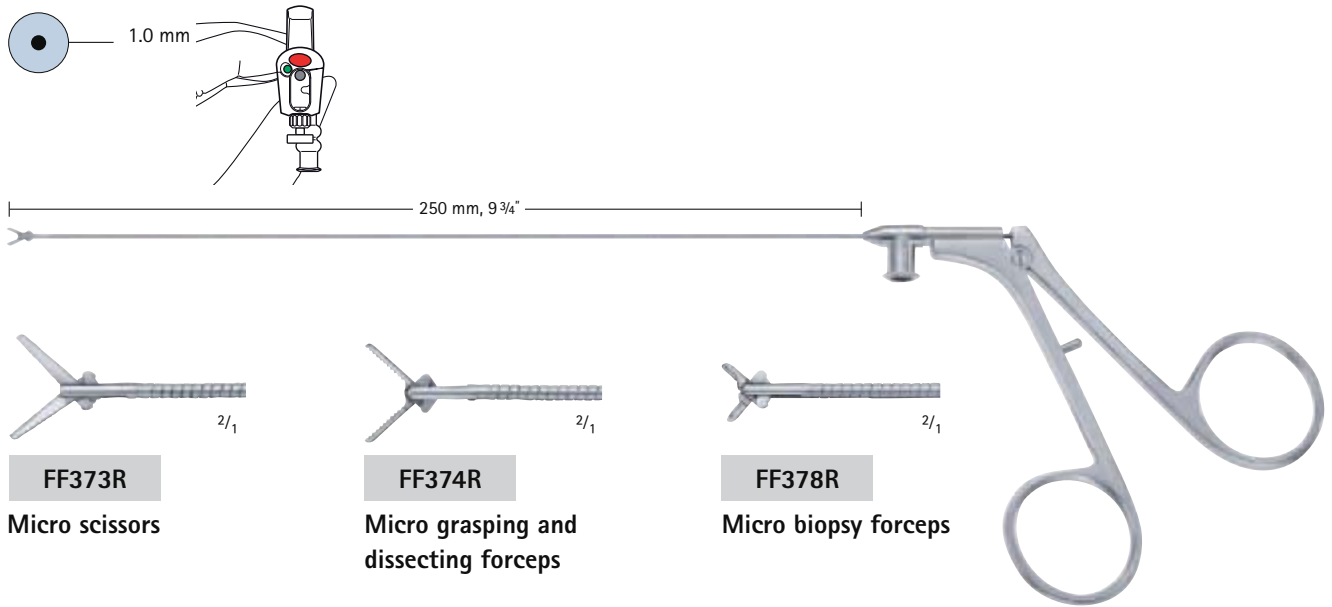

MINOP® InVent – Storage

FH358R

Storage rack for MINOP® InVent trocar and scope
with silicone protection and cushioning bottom and lid
Only for reprocessing, not for transportation/shipment

L/W/H 540 x 253 x 56 mm



FH359R

Storage rack for MINOP® InVent instruments and electrodes
with silicone protection and cushioning bottom and lid
Only for reprocessing, not for transportation/shipment

L/W/H 540 x 253 x 166 mm

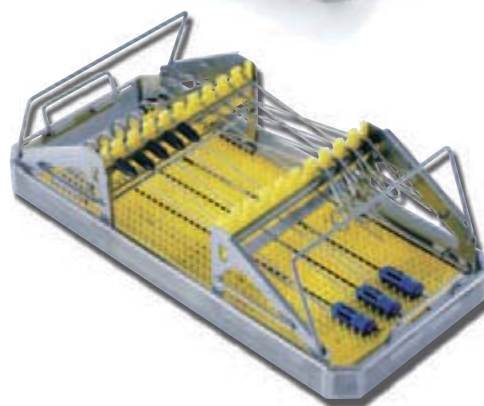

JK440

Container body 1/1
for FF358R
without base perforation

Outside/Inside dimensions
with lid:

L/W/H 592 x 285 x 112 mm

L/W/H 544 x 258 x 75 mm

JK444

Container body 1/1
for FF359R
without base perforation

Outside/Inside dimensions
with lid:

L/W/H 592 x 285 x 209 mm

L/W/H 544 x 258 x 172 mm

JK486

Container lid 1/1
blue

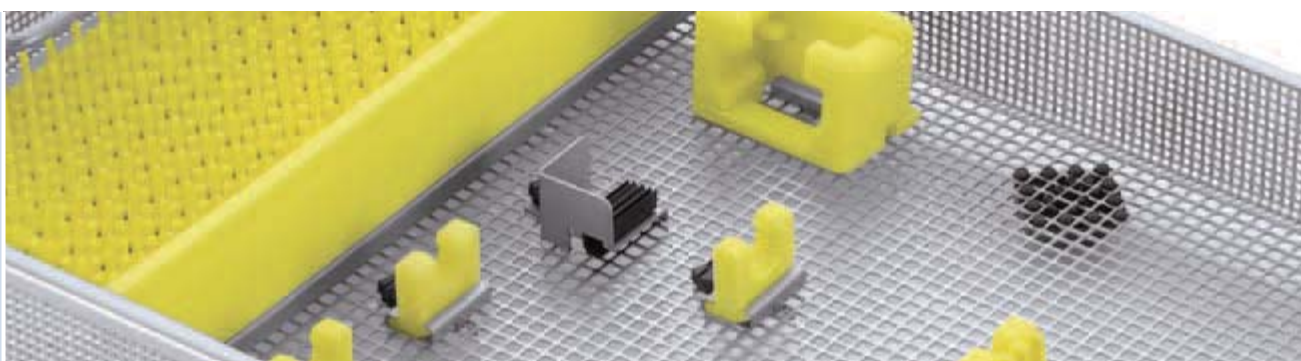

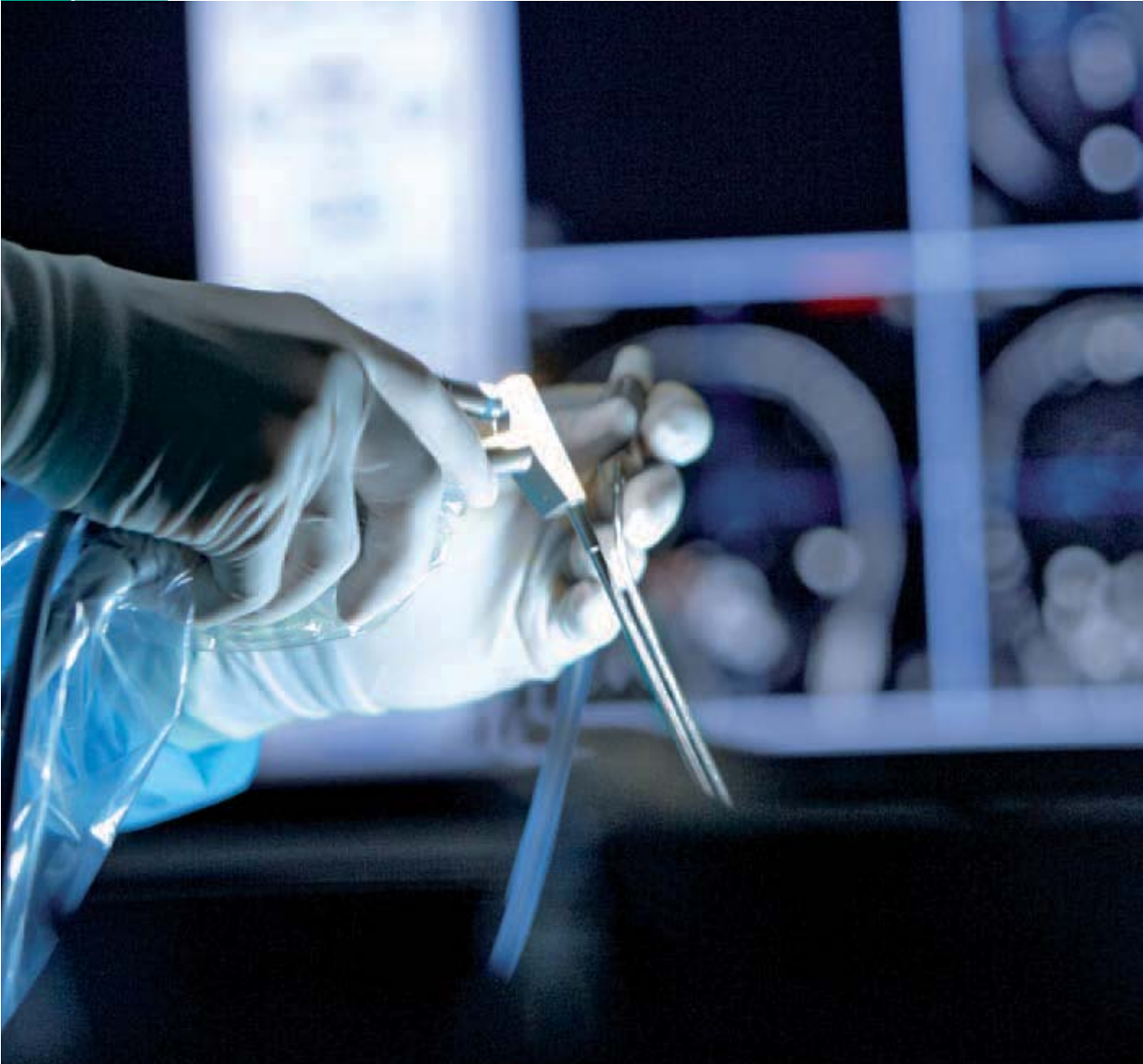
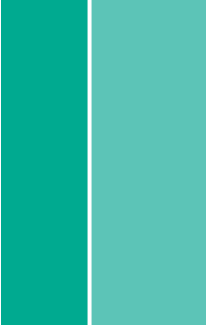

Endoscope-Assisted Microneurosurgery



MINOP® TEAM

Transcranial Endoscope Assisted Microneurosurgery

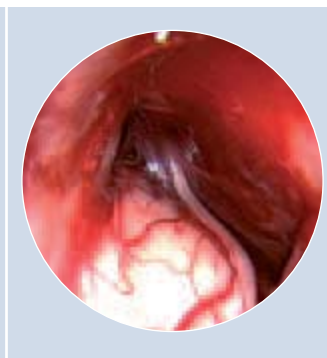
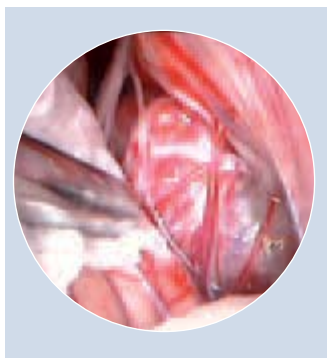

“ The aim of minimally invasive neurosurgery is to avoid approach-related traumatization of the patient by creating a tailor-made limited craniotomy based on skilled preoperative planning.

Using modern diagnostic tools, surgical instruments and visual equipment, the specific anatomy and pathology of the individual patient can be precisely visualized and anatomical pathways and surgical corridors determined for the surgical approach. According to the predefined access, surgical dissection can be subsequently performed creating a much less traumatic cranial opening. The aim is not the limited cranial opening, but the limited approach associated injury with less brain exploration and retraction. The craniotomy should be as small as possible for minimally invasive exposure, but as large as necessary for achieving maximal surgical effect. In this way, limited exposure is not the primary goal but the result of the keyhole concept with the main and most important goal being to avoid surgery-related complications.

The intraoperative use of microscopes is mandatory in keyhole neurosurgery. The operating microscope provides both stereoscopic magnification and illumination of the surgical field. However, the loss of light intensity in the depth of the surgical field is a fundamental problem in keyhole approaches. For the purpose of bringing light into the site, operating microscopes can effectively be combined with the intraoperative use of modern endoscopes. The advantages of the endoscopic image are increased light, extended viewing angle and a better depiction of anatomical details in close-up. The endoscope

is especially ideal for obtaining a detailed view of structures in the shadow of the microscope's light beam. Thus, in situations during microsurgical dissection where additional visual information of the target area is desired or when avoidance of retraction of superficial structures is recommended, an endoscope may be introduced into the surgical site.

The use of dedicated microneurosurgical instruments is obligatory in transcranial endoscope-assisted microneurosurgery. Highly sophisticated instrumentation including microdrills, Kerrison micropunches, self-retaining retractors, suction tubes, fine bipolar forceps, microscissors, diamond knives, microforceps, microdissectors, microcurettes, and clip applicators are mandatory for microsurgical dissection.

All before mentioned surgical tools - the microscope, endoscope and dedicated surgical instruments - complement each other and contribute in a TEAM-work manner to the goal of the keyhole concept: the achievement of the smallest iatrogenic trauma with the highest therapeutic effect for the patients.”

Peter Nakaji
Nikolai Hopf



Peter Nakaji
Phoenix, USA



Nikolai Hopf
Stuttgart, Germany

MINOP® TEAM

Transcranial Endoscope Assisted Microneurosurgery

Angled "Perneczky" Scopes

- FULL HD compatible, diam. 4.0 mm
- Brilliant image, rod lens system and different viewing directions (0°, 30°, 70°)
- Angled endoscope design and lateral connection for camera and light source
- Ergonomic handling by centered balance of weight
- Permits parallel microscope image
- Free area around the scope shaft for parallel use of micro instruments
- Autoclavable/Steris®/Sterrad®
- Robust and rigid scope sheath enables the scope to be used as dissector, manipulating delicate structures without bending the scope.

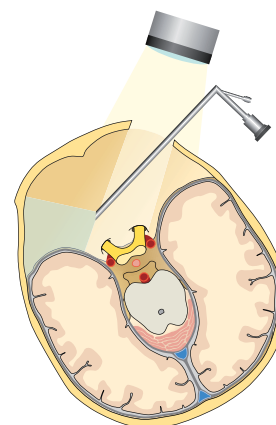

PE486A

Angled endoscope

Direction of view: 0°

Shaft diameter: 4 mm

Shaft length: 150 mm, 6"

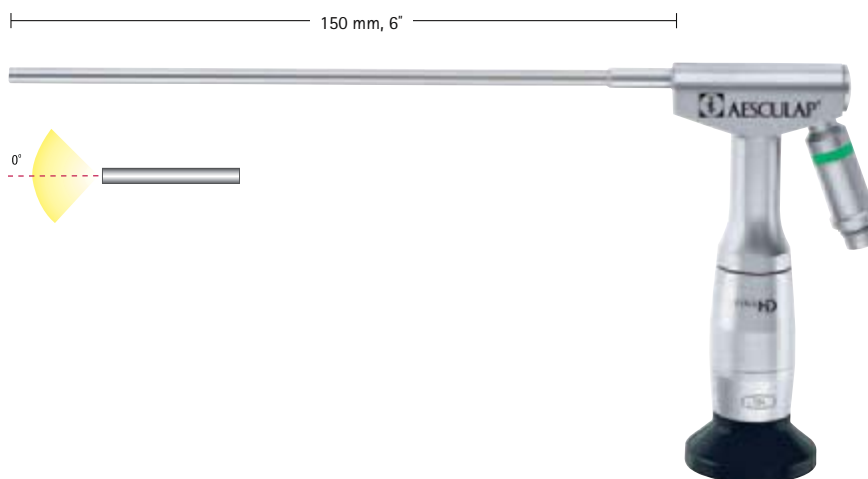

“ I have been using the Aesculap angled Perneczky scopes since the mid nineties and in over 1000 cases. I have trialed many different scopes for endoscope-assisted surgery but the Perneczky scopes have the versatility that I need when removing tumors from many different cranial locations. The main advantage of the angled scopes is the unique design that allows simultaneous use of endoscope and microscope. Other important qualities that are met by this system are robustness, ability to use it to retract if necessary and clarity of image. I believe these scopes are an essential tool in the neurosurgeon's armamentarium. ”

Charles Teo, Sydney, Australia



PE506A

Angled endoscope

Direction of view: 30°, upwards

Shaft diameter: 4 mm

Shaft length: 150 mm, 6"

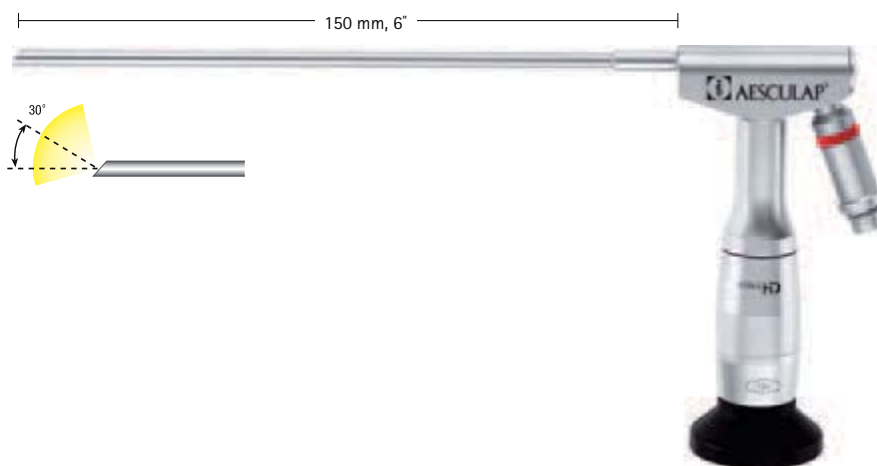

PE526A

Angled endoscope

Direction of view: 70°, upwards

Shaft diameter: 4 mm

Shaft length: 150 mm, 6"

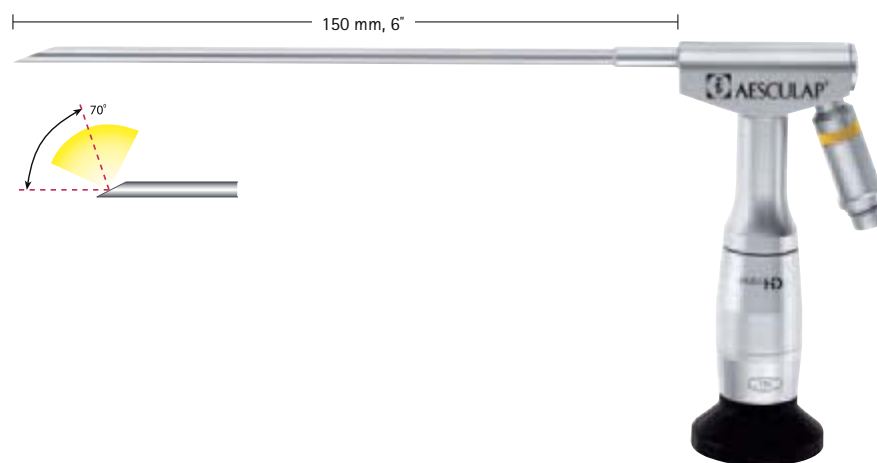

JF324R

Storage tray

with silicone cushioning racks and lid

for 2 angled neuroscopes (not included)

(L/W/H 247 x 257 x 64 mm)



“ During microneurosurgical skull base approaches for either vascular lesions or tumors, there is often a difficulty of visualizing important neurovascular structures around and behind the lesion. In such a situation, the use of endoscopes has greatly advanced my surgical possibilities. The additional view through the endoscopes, which is complementary to what can be seen through the operating microscope, facilitates the handling of the lesion, be it aneurysm clipping or tumor removal, while at the same time there is no need for extensive retraction or bone removal. ”

André Grotenhuis, Nijmegen, Netherlands



MINOP® TEAM

Transcranial Endoscope Assisted Microneurosurgery

Aesculap Micro Instruments

Small craniotomies or narrow operative sites require especially designed fine and slender micro instruments

Experience our three different lines of minimally invasive Micro Instruments

page 43 -48

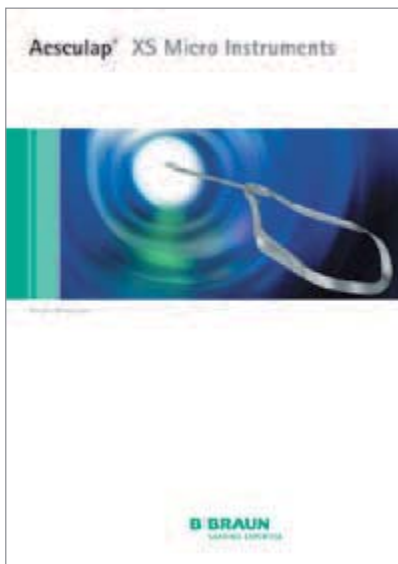

For more information about XS Micro Instruments please see our brochure C77011

page 49 - 58

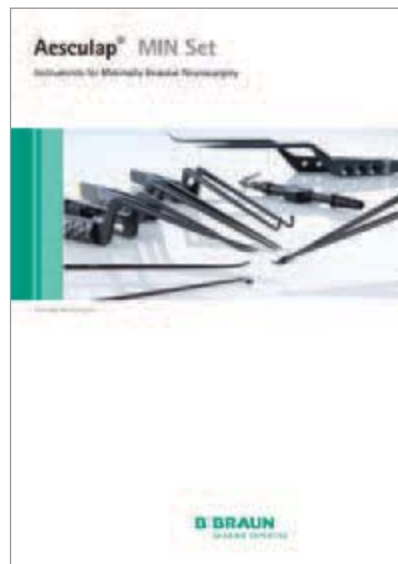

For more information about MIN Set please see our brochure C92011



For more information about SENSATION Micro Instruments please see our brochure C84902

XS Tube Shaft Micro Instruments

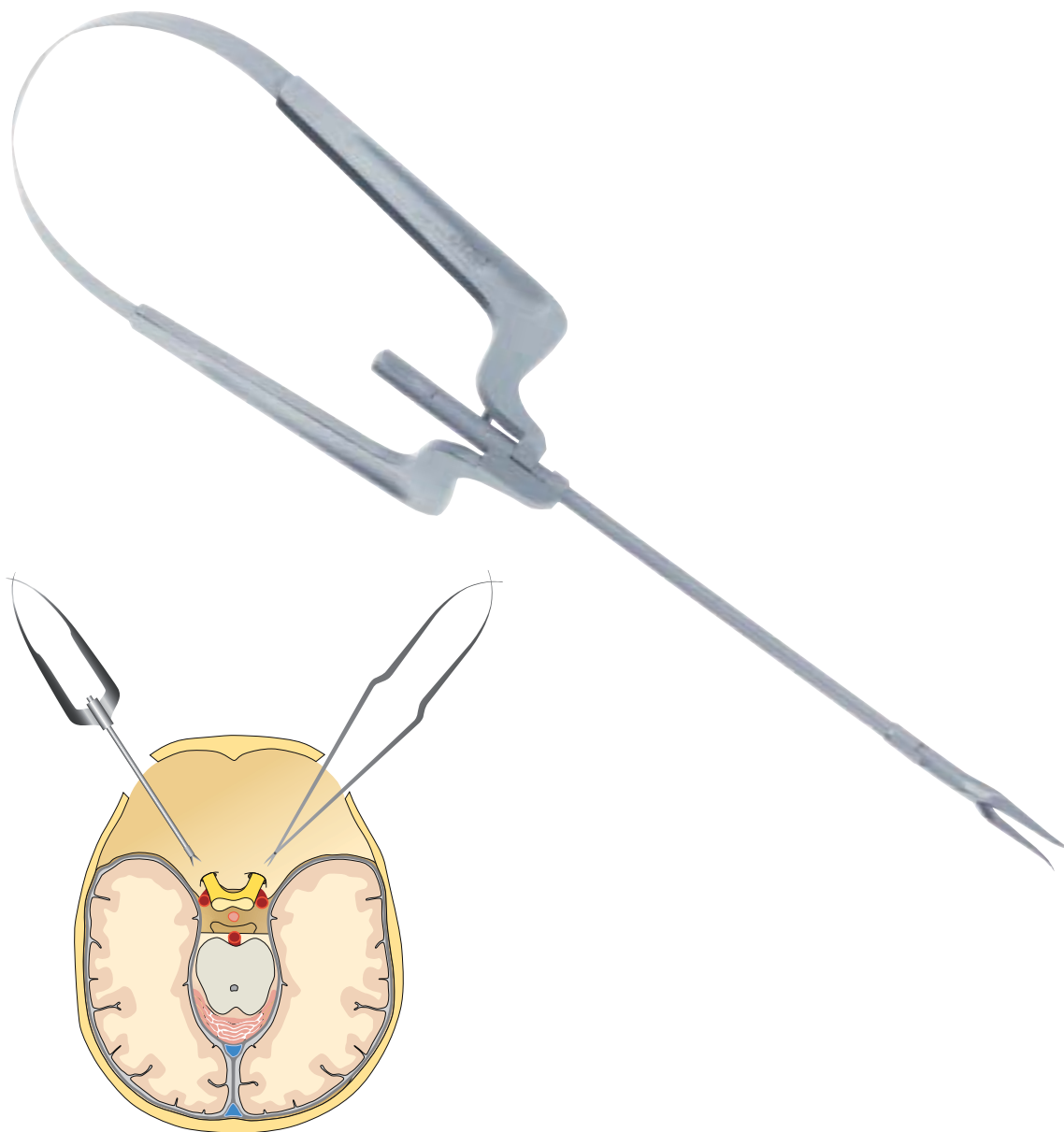

“ Performing limited keyhole approaches, the application of conventional microsurgical instruments becomes limited in several cases. Slender keyhole microinstruments have been specially created to overcome this problem allowing unhindered introduction of the tool through the limited craniotomy. These XS tube-shaft designed instruments can be used in very small operating corridor enabling safe manipulation within the narrow surgical passage and obvious visualisation of the surgical field. ”



Robert Reisch, Zurich, Switzerland

MINOP® TEAM

Transcranial Endoscope Assisted Microneurosurgery

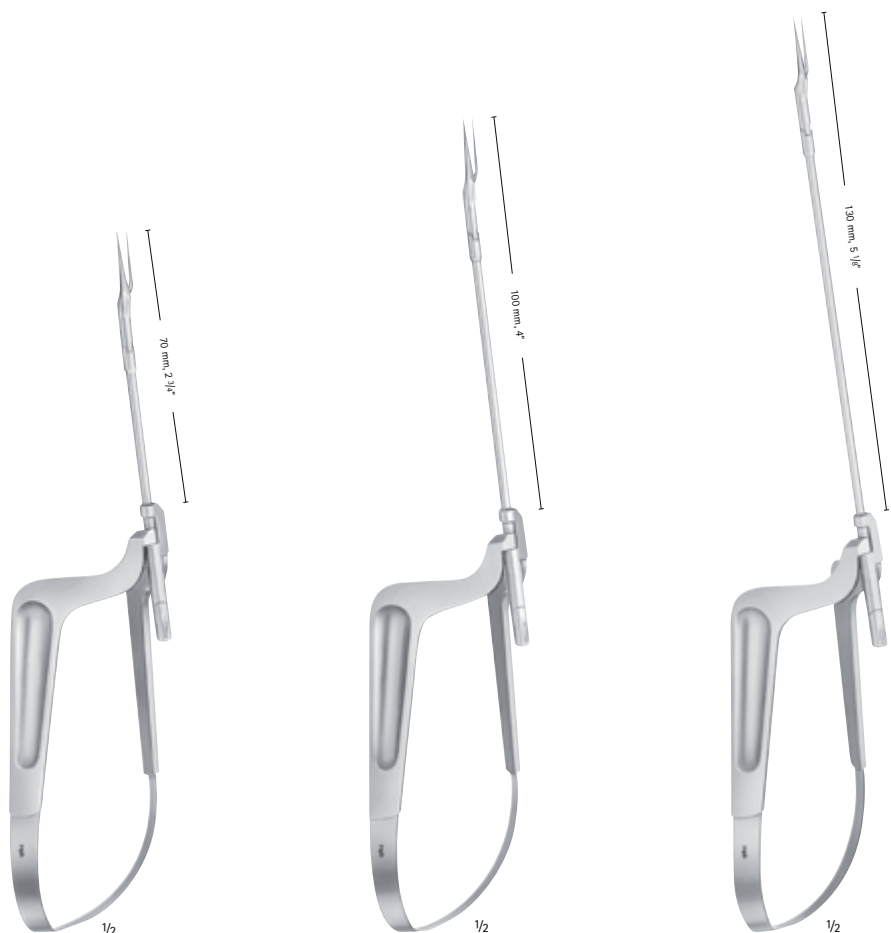
XS Tube Shaft Micro Instruments

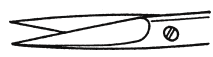

	Instrument complete	Single parts		Instrument complete	Single parts		Instrument complete	Single parts	
		Jaw insert	Handle		Jaw insert	Handle		Jaw insert	Handle
straight jaws sharp/sharp 	FM670R	FM675R	FM730R	FM671R	FM676R	FM731R	FM672R	FM677R	FM732R
blunt/blunt 	FM690R	FM695R		FM691R	FM696R		FM692R	FM697R	
Jaw length	70 mm, 2 3/4"			100 mm, 4"			130 mm, 5 1/8"		
Total length	200 mm, 8"			230 mm, 9"			260 mm, 10 1/4"		

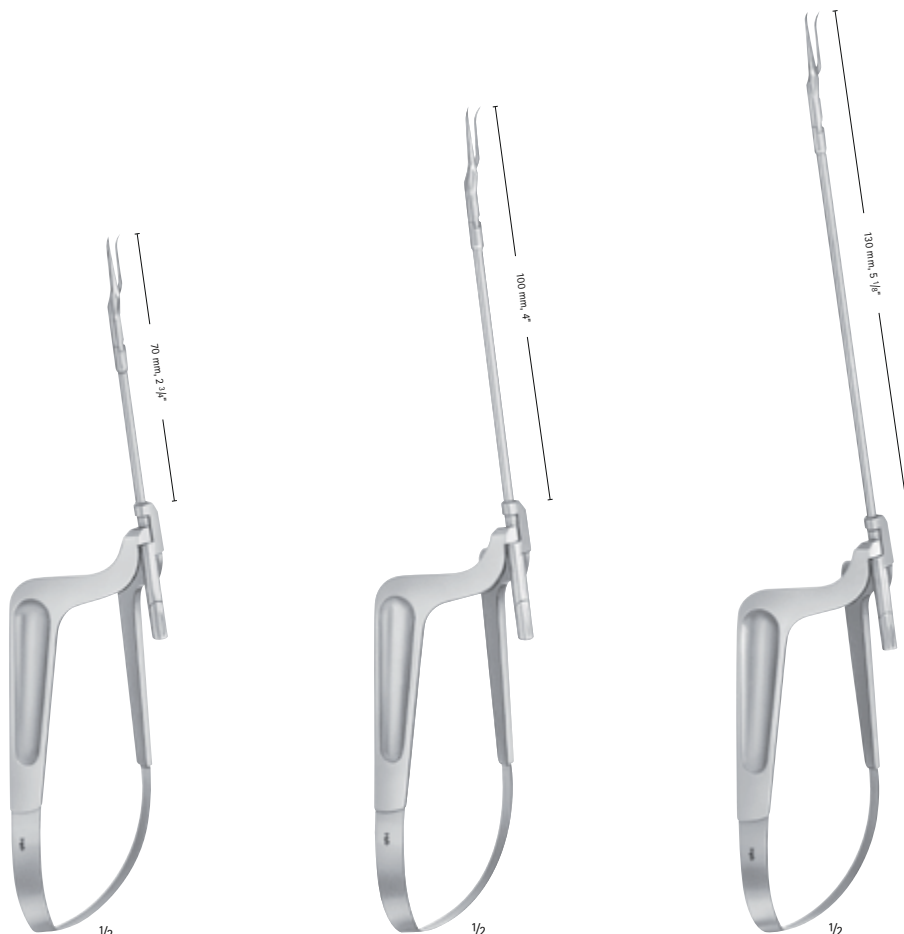

	1/2			1/2			1/2		
	Instrument complete	Single parts		Instrument complete	Single parts		Instrument complete	Single parts	
		Jaw insert	Handle		Jaw insert	Handle		Jaw insert	Handle
curved jaws sharp/sharp	FM680R	FM685R	FM730R	FM681R	FM686R	FM731R	FM682R	FM687R	FM732R
blunt/blunt	FM700R	FM705R		FM701R	FM706R		FM702R	FM707R	
Jaw length	70 mm, 2 3/4"			100 mm, 4"			130 mm, 5 1/8"		
Total length	200 mm, 8"			230 mm, 9"			260 mm, 10 1/4"		



MINOP® TEAM

Transcranial Endoscope Assisted Microneurosurgery

XS Tube Shaft Micro Forceps acc. PERNECZKY/CHRISTIANE

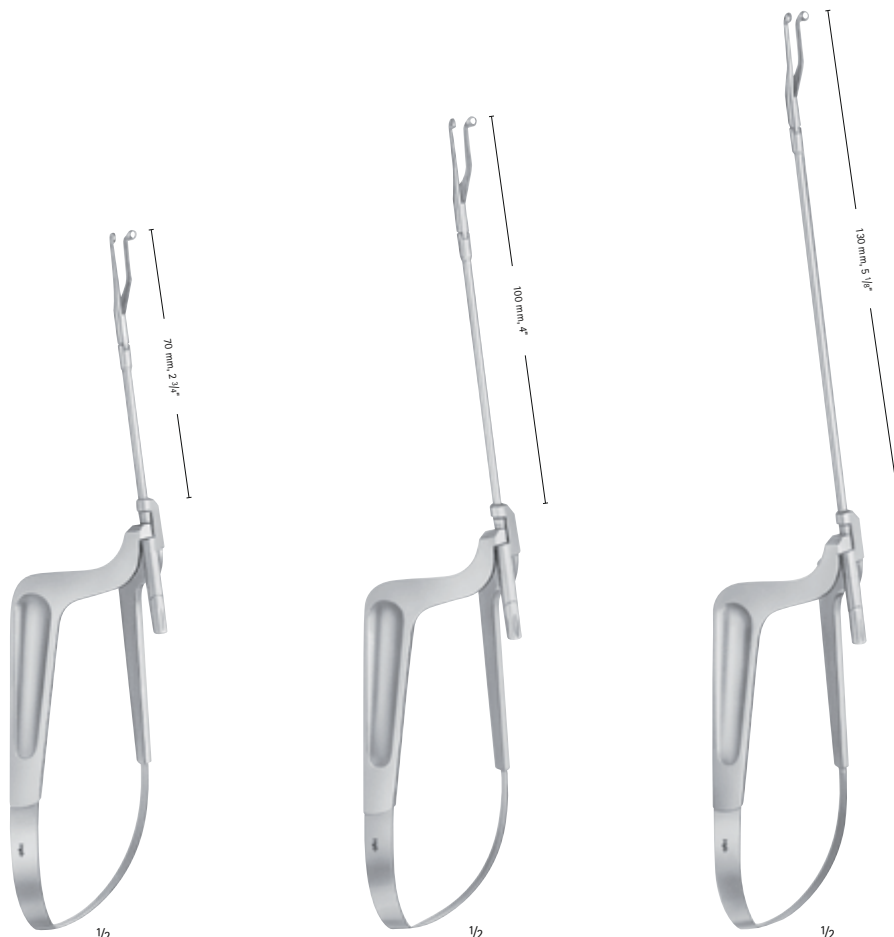

Jaw 3 mm, sharp	Instrument complete	Single parts		Instrument complete	Single parts		Instrument complete	Single parts	
		Jaw insert	Handle		Jaw insert	Handle		Jaw insert	Handle
	FM725R	FM725R	FM730R	FM721R	FM726R	FM731R	FM722R	FM727R	FM732R
Jaw length	70 mm, 2 3/4"			100 mm, 4"			130 mm, 5 1/8"		
Total length	200 mm, 8"			230 mm, 9"			260 mm, 10 1/4"		

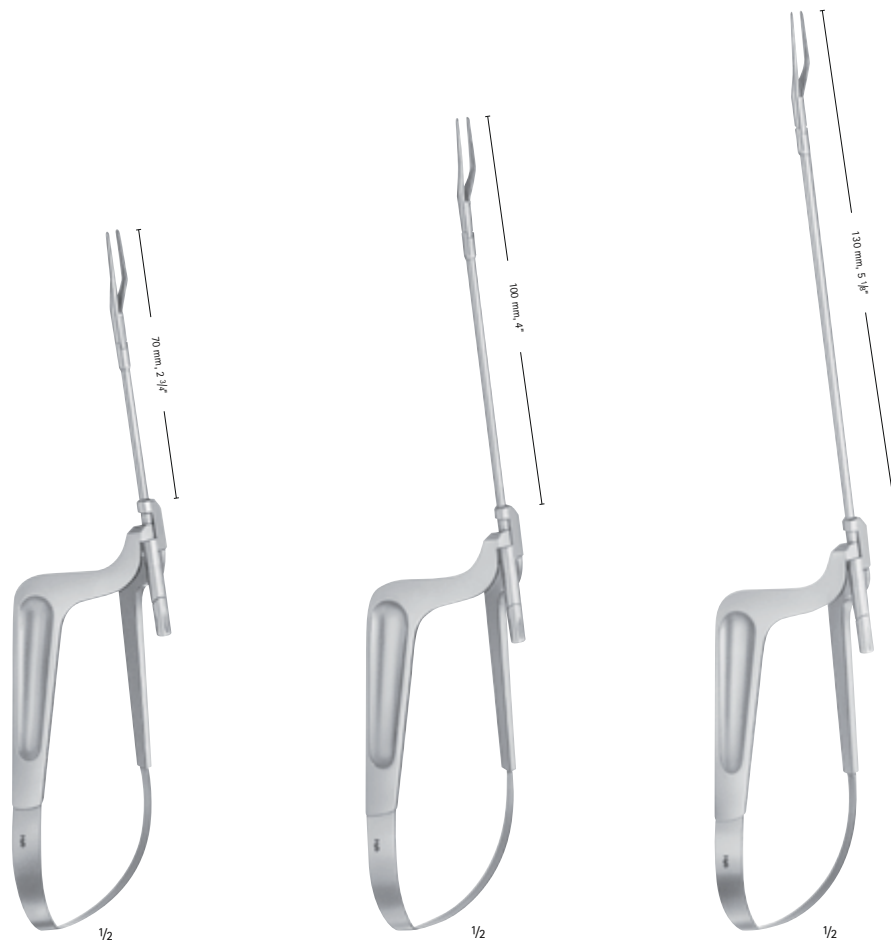

Jaw 0.9 mm	Instrument complete			Single parts			Instrument complete			Single parts		
	FM710R	FM715R	FM730R	FM711R	FM716R	FM731R	FM712R	FM717R	FM732R			
Jaw length	70 mm, 2 3/4"			100 mm, 4"			130 mm, 5 1/8"					
Total length	200 mm, 8"			230 mm, 9"			260 mm, 10 1/4"					

MINOP® TEAM

Transcranial Endoscope Assisted Microneurosurgery

XS Tube Shaft Aneurysm Clip Applying Forceps

- 360° rotation
- suitable for narrow approaches



	Standard	Mini
For Titanium clips	FT495T	FT490T
For Phynox clips	FE495K	FE490K



	Standard	Mini
For Titanium clips	FT496T	FT491T
For Phynox clips	FE496K	FE491K

“ The cause for the significant superiority of the endovascular treatment of aneurysms compared with the surgical therapy in the ISAT study was the surgical morbidity and mortality of large sized standard approaches. In my opinion, surgical clipping will play an important role in the treatment of intracranial aneurysms in the future only, if it will be able to reduce approach related complications using limited craniotomies. The use of endoscope-assisted techniques and tube-shaft clip applicators offer increased safety in keyhole vascular neurosurgery, thus achieving the basic goal with minimally invasive and maximal effective aneurysm closure. ”



Robert Reisch, Zurich, Switzerland

MIN Instruments



Slender design and angled bayonet shape

Improved visibility of the surgical site due to the slender design. Angled bayonet shape allows for less obstructions while working under the microscope.



Round golf ball handle design

Designed to provide an excellent grip and enable easy rotation of the instruments. This allows precise handling.



Various working lengths

One handle design aligned with precisely adapted working lengths. Always provides the right instrument at your fingertips!



Noir[®], No Irritating Reflections

Aesthetic surface coating effectively prevents disturbing light reflections.



Fine instrument tips

Especially important when working in very small operating corridors and close to sensitive structures.





MINOP® TEAM

Transcranial Endoscope Assisted Microneurosurgery

MIN Micro Scissors

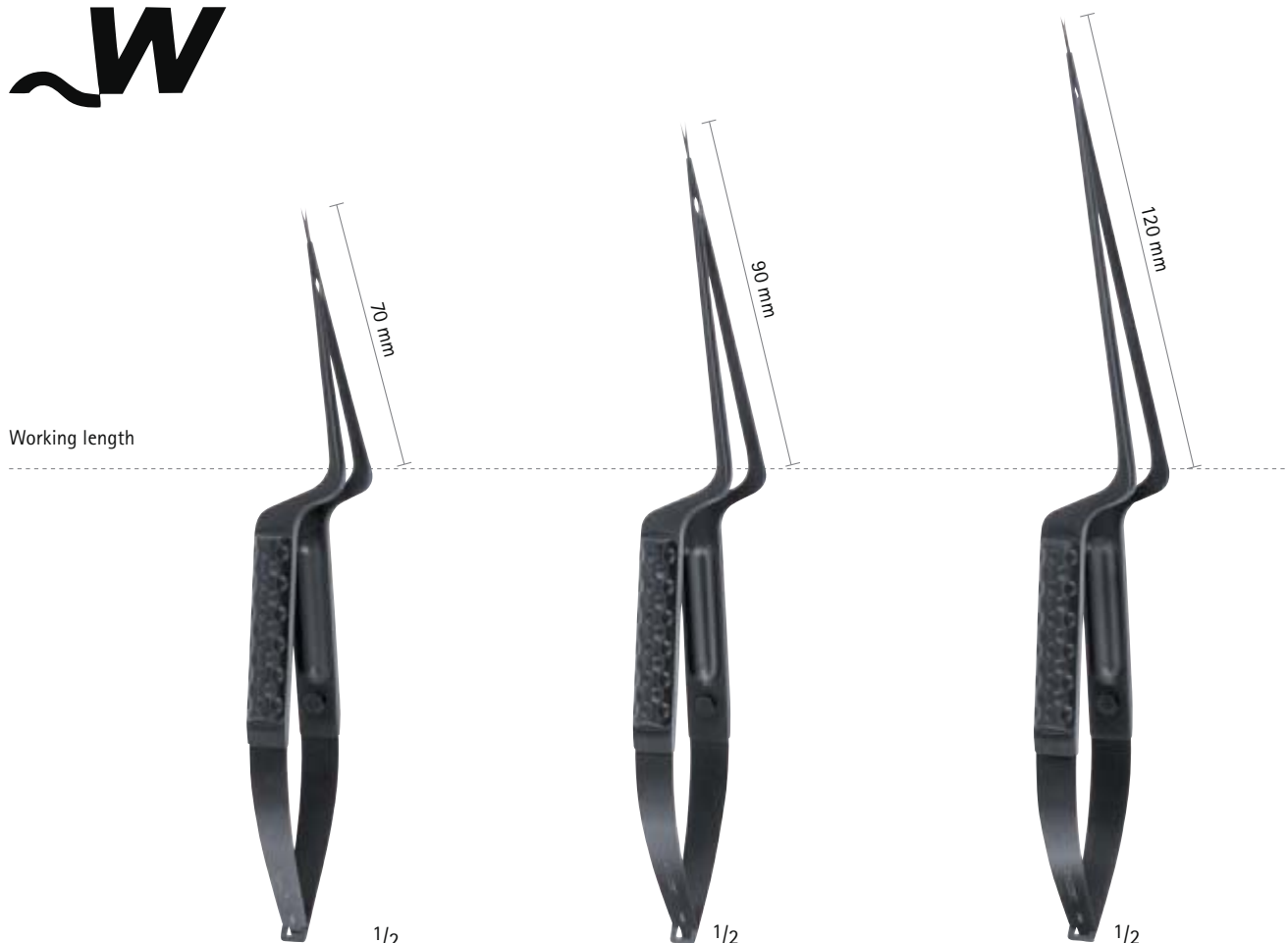
All scissors are equipped with wavecut



	straight	s.curved	curved	straight	s.curved	curved	straight	s.curved	curved
	FD701B	FD702B	FD703B	FD731B	FD732B	FD733B	FD771B	FD772B	FD773B
	FD704B	FD705B	FD706B	FD734B	FD735B	FD736B	FD774B	FD775B	FD776B
Working length	70 mm	70 mm	70 mm	90 mm	90 mm	90 mm	120 mm	120 mm	120 mm
Total length	200 mm	200 mm	200 mm	220 mm	220 mm	220 mm	250 mm	250 mm	250 mm



For more information to MIN Instruments, please ask your local Aesculap sales representative or see our Brochure C92011

MIN Micro Needle Holder

Working length

70 mm

90 mm

120 mm

2/1

For suture material size 7/0 and smaller.

All needle holders are equipped with ratchets

	FD717B	FD718B	FD719B
Working length	70 mm	90 mm	120 mm
Total length	200 mm	220 mm	250 mm



MINOP® TEAM

Transcranial Endoscope Assisted Microneurosurgery

MIN Tissue and Tumor Grasping Forceps

DIADUST

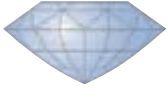

0.5 mm	
0.9 mm	
Working length	
Total length	



FD711B
70 mm
190 mm

FD741B
FD743B
90 mm
210 mm

FD761B
FD763B
120 mm
240 mm









	straight		45° curved		90° curved	
2.5 mm 	FD766B	FD786B	FD767B	FD787B	FD768B	FD788B
3.5 mm 	FD769B	FD789B	-	-	-	-
Working length	90 mm	120 mm	90 mm	120 mm	90 mm	120 mm
Total length	210 mm	240 mm	210 mm	240 mm	210 mm	240 mm

1/2







MINOP® TEAM

Transcranial Endoscope Assisted Microneurosurgery

MIN Micro Instruments



		Noir® Modular Handles	
		FD811B	Handle, 8 mm, 100 mm
		FD812B	Handle, 11 mm, 100 mm
1/2			
		Noir® Probes / Hooks	
		FD797B	Probe ball-tip, 200 mm, 0°
		FD798B	Probe ball-tip, 200 mm, 45°
		FD799B	Probe ball-tip, 200 mm, 90°
		FD808B	Hook, blunt, 200 mm, 45°
		FD809B	Hook, blunt, 200 mm, 90°
		FD805B	Hook, sharp, 200 mm, 90°
1/1			
		Noir® Scoops	
		FD814B	Scoop, 200 mm, 2 mm, 10°
		FD815B	Scoop, 200 mm, 2 mm, 45°
		FD816B	Scoop with neck, 200 mm, 2 mm, 45°
1/1			
		Noir® Dissectors	
		FD821B	Dissector, curved, 200 mm, 1 mm
		FD822B	Dissector, curved, 200 mm, 2 mm
		FD823B	Dissector, curved, 200 mm, 3 mm
1/1			

Noir® Currettes

	FD824B	Curette, 200 mm, diam. 4 mm, 0°
	FD825B	Curette, 200 mm, diam. 4 mm, 45°
	FD826B	Curette, 200 mm, diam. 4 mm, 90°
	FD827B	Curette with neck, 200 mm, diam. 4 mm, 45°
	FD828B	Curette with neck, 200 mm, diam. 4 mm, 90°
	FD835B	Curette, 200 mm, diam. 6,5 mm, 45°
	FD836B	Curette, 200 mm, diam. 6,5 mm, 90°



1/1

Noir® Rasparatories

	FD831B	Rasparatory, 200 mm, 1 mm
	FD832B	Rasparatory, 200 mm, 2 mm
	FD833B	Rasparatory, 200 mm, 3 mm

1/1

Noir® Tumor knives

	FD839B	Noir Tumor knife, 200 mm, diam. 1,5 mm, 45°
	FD840B	Noir Tumor knife, 200 mm, diam. 3 mm, 45°
	FD841B	Noir Tumor knife, 200 mm, diam. 4,5 mm, 45°

1/1

FD467R	Tray
---------------	------



MINOP® TEAM

Transcranial Endoscope Assisted Microneurosurgery

MIN Pivot-Point Bipolar Forceps

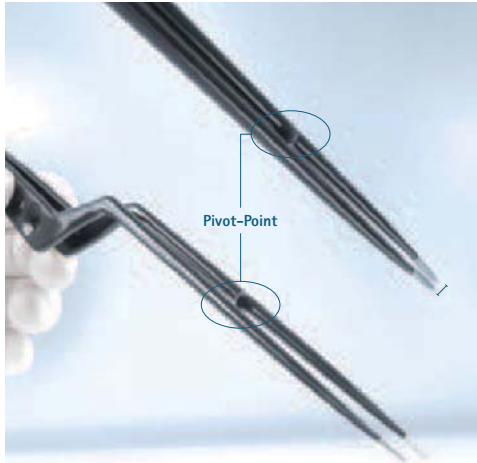

“ The black „pivot“ bipolar forceps are a great advance. The bipolar is as essential a tool as the neurosurgeon’s own fingers. As we go more and more minimally invasive, the need for a very slim, responsive bipolar that will work under tight conditions is essential. The tips can be precisely separated even when the shafts are together in a tiny space. This is a must-have instrument, especially for transphenoidal and keyhole approaches. ”

Peter Nakaji, Phoenix, USA



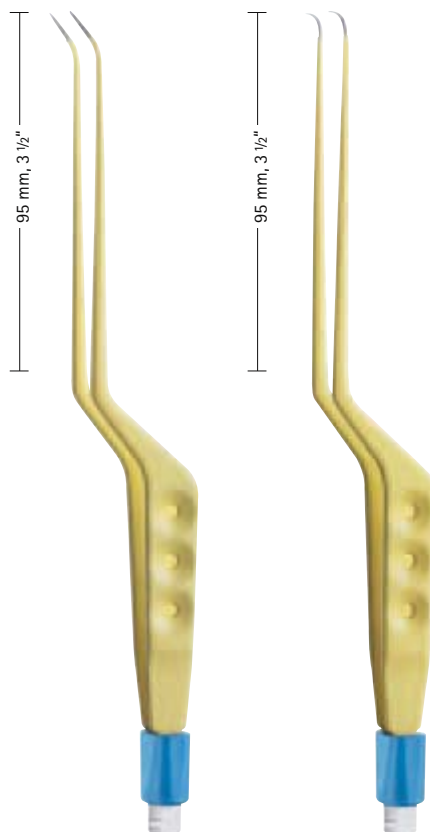

Bipolar Yasargil Forceps

Bipolar Yasargil forceps:
extra-small bipolar forceps for
keyhole approaches

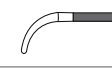

 Aesculap tab

0.4 mm	
0.7 mm	
0.7 mm	
Working length	
Total length	

		GK780R
GK777R		
		GK781R
Working length	95 mm	135 mm
Total length	215 mm, 8 1/2"	215 mm, 8 1/2"



For more information please ask your local Aesculap sales representative or see our Brochure C30481

MINOP® TEAM

Transcranial Endoscope Assisted Microneurosurgery

MIN Modular Suction Cannulas

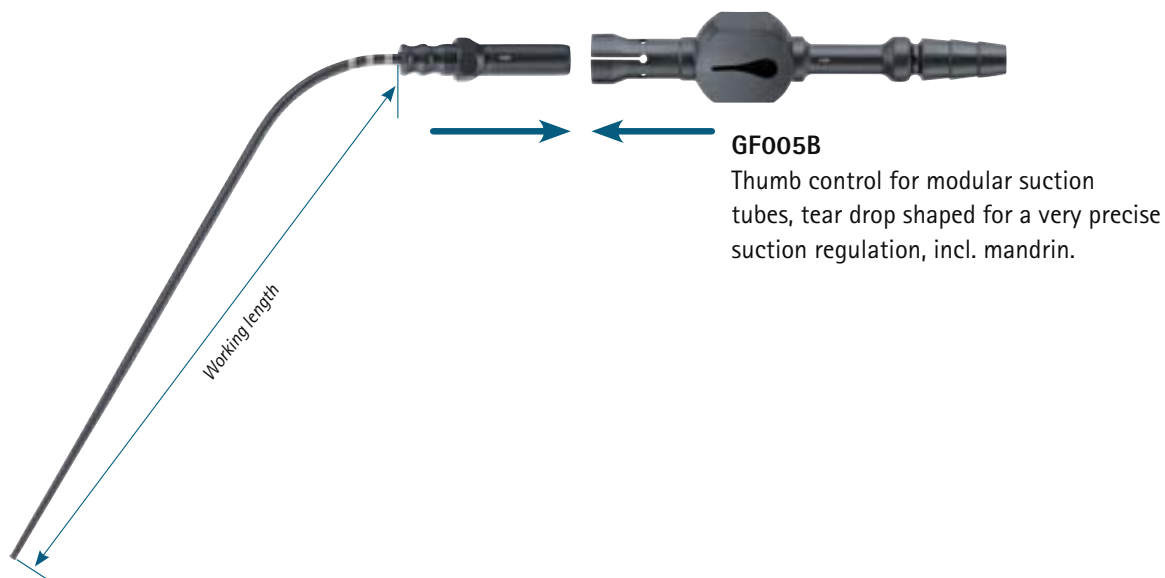

GF005B
Thumb control for modular suction tubes, tear drop shaped for a very precise suction regulation, incl. mandrin.

	○ S	○○ M	○○○ L	○○○○ LL	
Working length	80 mm	100 mm	120 mm	140 mm	
4 Fr. straight	○	GF025B	GF035B	GF045B	GF055B
6 Fr. straight	○	GF026B	GF036B	GF046B	GF056B
6 Fr. straight, lateral holes	◇	-	GF038B	GF048B	GF058B
6 Fr. curved left	○	-	GF030B	-	-
6 Fr. curved right	○	-	GF031B	-	-
8 Fr. straight	◎	GF027B	GF037B	GF047B	GF057B
8 Fr. straight, lateral holes	◎	-	GF039B	GF049B	GF059B
8 Fr. curved left	◎	-	GF032B	-	-
8 Fr. curved left	◎	-	GF033B	-	-

3 Fr. = 1 mm

Benefits...

- Atraumatic tips enable blunt dissection and retraction
- Lateral bore holes reduce suction pressure
- Damaged suction tubes can be replaced individually
- Tray weight is reduced and less space is required
- Greater freedom for even more flexible use



Atraumatic Micro Suction Instruments

Micro suction cannulas:

Atraumatic and rigid suction cannulas



Color code		Working length 80 mm ●	Working length 100 mm ●●	Working length 120 mm ●●●	Working length 140 mm ●●●●
yellow, 1.4 mm	4 Fr ○ 1/4	GF470R	GF473R	GF476R	GF479R
blue, 2.0 mm	6 Fr ◎ 1/4	GF471R	GF474R	GF477R	GF480R
green, 2.7 mm	8 Fr ○ 1/2	GF472R	GF475R	GF478R	GF481R

3 Fr = 1 mm



The ball tip at the end of the instrument allows gentle preparation and stable atraumatic retraction.



Colour coding for rapid identification of all three diameters. Black Rings as indicators to identify the instrument length.

In endoscope-assisted approaches to complex structures like fine vessels or aneurysms, Micro-Cannulas are reassuringly safe due to the delicate instrument tip. During preparations in conjunction with a bipolar forceps the Micro-Cannula offers a safe and stable retraction.

MINOP® TEAM

Transcranial Endoscope Assisted Microneurosurgery

TREND Currettes and Dissectors

TREND instruments
Bayonet instruments for
pituitary and skull base

FA041R-FA068R

Working length:
130 mm, 5 1/8"

Total length:
280 mm, 11"



NICOLA
FA041R
Curette
diam. 6.5 mm
45° vertical
angled long
neck



NICOLA
FA042R
Curette
diam. 6.5 mm
45° horizontal
angled short
neck



HARDY
FA043R
Enucleator
left cutting



HARDY
FA044R
Enucleator
right cutting



HARDY
FA045R
Curette
diam. 4.0 mm
90° left angled
long neck



HARDY
FA046R
Curette
diam. 4.0 mm
90° left angled
short neck



HARDY
FA047R
Curette
diam. 4.0 mm
90° right angled
long neck



HARDY
FA060R
Curette
diam. 4.0 mm
90° right angled
short neck

“ Compared to a classical curette instrument, the TREND currettes provide highly ergonomic grasping with a well-balanced weight distribution and a perfect grip. This significantly supports the curette movements when the instrument is inserted vertically into smaller craniotomies, e.g. keyhole approaches. As the TREND instruments come in bayonet and straight design, I use them for both microscopic minimally invasive keyhole surgery and endoscope-assisted approaches. ”

Nikolai Hopf, Stuttgart, Germany

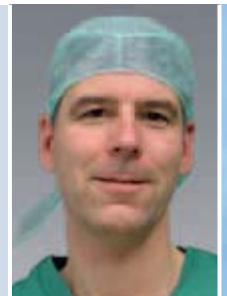



HARDY
FA061R
 Curette
 diam. 4.0 mm
 45° left
 horizontal angled
 short neck



HARDY
FA062R
 Curette
 diam. 4.0 mm
 45° right
 horizontal angled
 short neck



HARDY
FA063R
 Curette
 diam 6.0 mm
 90° left angled
 long neck



HARDY
FA064R
 Curette
 diam. 6.0 mm
 90° left angled
 short neck



HARDY
FA065R
 Curette
 diam. 6.0 mm
 90° right angled
 long neck



HARDY
FA066R
 Curette
 diam. 6.0 mm
 90° right angled
 short neck



REULEN-
 LANDOLT
FA067R
 Micro Hook
 diam. 1.7 mm



REULEN-
 LANDOLT
FA068R
 Dissector
 diam. 2.0 mm
 blunt



MINOP® TEAM

Transcranial Endoscope Assisted Microneurosurgery

Diamond Knives

Diamond knives

Blade made of natural diamond

Superior mechanical stability
& elasticity of the blade

Sustained sharpness

Excellently clean, precise
and force-free incisions

Protection mechanism for
storage of the blade inside
the handle

Color coded Titanium handles



FD113D

Round blade,
gold-colored

7 facets
Length
205 mm, 8"



FD114D

Retro blade,
copper-colored

60°
Length
205 mm, 8"



FD115D

Wedge blade,
black-colored

45°
Length
205 mm, 8"



FD116D

Lancet blade,
bronze-colored

60°
Length
205 mm, 8"

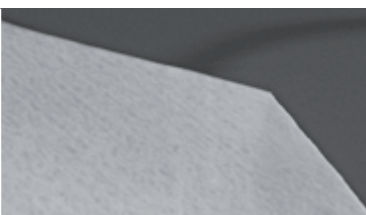
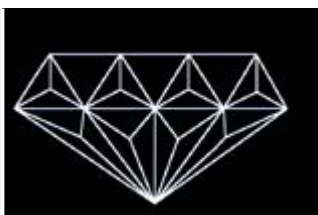

SEM view of a diamond knife blade

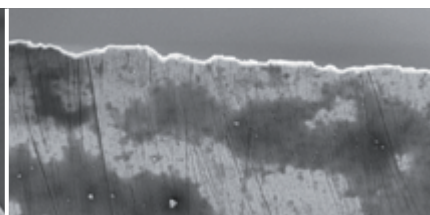

SEM view of a common scalpel blade

NOIR® Brain Spatulas

NOIR® brain spatulas

NOIR® (NO Irritating Reflections)

Less light reflections under the
endoscope light

Length 200 mm, 8"



“Important goal in minimally invasive keyhole approaches is to avoid unnecessary brain exploration and retraction. With accurately tailored limited craniotomy and patients adequate positioning this ambition can be achieved in most cases. Nevertheless, if retraction cannot be avoided or brain surface must be protected, the use of a sensitive brain spatula is obligatory. With their conical shape, the NOIR® spatulas avoid extensive deep tissue retraction and provide excellent visualization of the field. In addition, the black coating avoids disturbing reflections using endoscope-assisted TEAM technique.”

Robert Reisch, Zurich, Switzerland

MINOP® TEAM

Transcranial Endoscope Assisted Microneurosurgery

NOIR® KERRISON Bone Punches – NOIR® (NO Irritating Reflections)

Jaw position 130°, upward opening

Shaft length	Width	Footplate	Article No.	Ejector	Jaw opening
180 mm, 7"	1.0 mm	standard	FK900B	-	8 mm
	1.5 mm	standard	FK911B	-	9 mm
	2.0 mm	standard	FK901B	✓	9 mm
	2.5 mm	standard	FK912B	✓	10 mm
	3.0 mm	standard	FK902B	✓	10 mm
200 mm, 8"	1.5 mm	standard	FK966B	-	9 mm
	2.0 mm	standard	FK913B	✓	9 mm
	2.5 mm	standard	FK967B	✓	10 mm
	3.0 mm	standard	FK914B	✓	10 mm



<p>At a glance, large numbered jaw identification</p>	<p>Ejector – for the easy removal of punched-out material.</p>	<p>Numerical code – for reliable identification when assembling the two punch components.</p>

KERRISON Bayonet Bone Punches

Jaw position 130°, upward opening

Length	Width	Working length	Article No.	Jaw width
240 mm, 9 1/2"	2.0 mm	170 mm	FF496R	10 mm
	3.0 mm	170 mm	FF497R	10 mm
	4.0 mm	170 mm	FF498R	10 mm
	5.0 mm	170 mm	FF499R	10 mm



For more information about MINOP® TEAM please see our „Practical Atlas“ C29802.



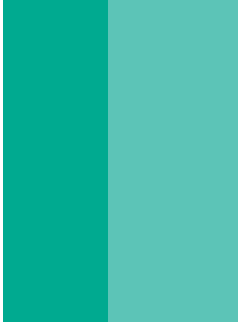

Transnasal Neuroendoscopy

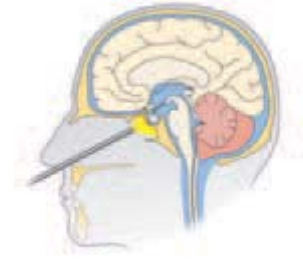

MINOP® TREND

TRansnasal ENDoscopic System

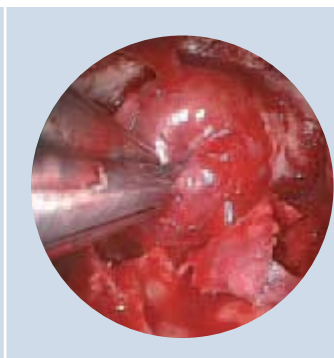
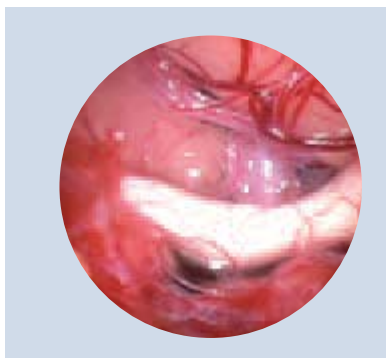



“ When looking at recent publications on transsphenoidal surgery, it will be clear that **TR**anssphenoidal **END**oscopy is TREND-setting! However, this endoscopic technique is not in routine use everywhere and neurosurgeons are often reluctant to use it: One is often cautious about an endoscopic endonasal dissection because the permanent contamination of the endoscope with blood and nasal secretions hinders orientation. In addition, the para-endoscopic and biportal dissection is very unfamiliar requiring an unacceptably steep learning curve.

Nevertheless, endoscopic visualization and para-endoscopic dissection without using the surgical microscope offers several undisputable advantages. Advantages in visualization increases light intensity in the deep-seated surgical field and clearly displays patho-anatomical details. In addition, the extended viewing angle of endoscopes enables surgeons to observe hidden parts of the surgical field. The major benefit in surgical dissection is the unhindered approach to these clearly visible structures: Without using a nasal speculum, surgical manipulation is not impeded and the instruments are freely mobile. In addition, a pure endoscopic technique avoids the need

for rhinoseptal submucosal dissection providing a direct and quicker approach to the sphenoid sinus. This method avoids the need for postoperative nasal packing, thus causing less pain and discomfort after surgery, providing better nasal airflow and a shorter hospital stay.

Pre-conditions of transsphenoidal endoscopy are the basic endoscopic experience and anatomical studies in the laboratory; however, it is indispensable to use a dedicated endoscopic system to further shorten the learning phase. The endoscope for transsphenoidal skull base surgery must provide a brilliant image quality with true colors, high contrast and highly realistic images. This simplifies the differentiation between healthy or pathological structures. It is essential to have an effective cleaning function in order to free the endoscope lens from fog, blood or mucosal secretions. The endoscope must offer a highly ergonomic design and sufficient working length for extended approaches. For selected cases, it is also necessary to connect the endoscope to a navigation system or a holding device.”

André Grotenhuis , Robert Reisch



André Grotenhuis
Nijmegen, Netherlands



Robert Reisch
Zurich, Switzerland

MINOP® TREND

TRansnasal ENDoscopic System

MINOP® TREND

FH615

Handle with irrigation button
for FH610R and FH611R
Ergonomic grasping part



RT099R

Adapter for Aesculap
holding arm



FH605SU

Suction and irrigation tube,
sterile, 4.5 m, 2 puncture needles,
for MINOP® TREND handle FH615
Package of 10 tubes



FF357R

Storage tray with silicone padding and lid
for all MINOP® TREND components
(L/W/H 410 x 257 x 64 mm)

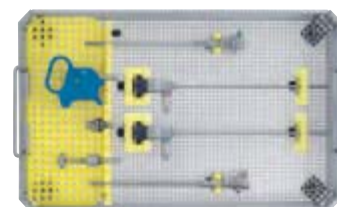

JK740

container body 3/4
with base perforation
Outside/Inside dimensions with lid:
L/W/H 470 x 285 x 112mm
L/W/H 421 x 258 x 75mm



JK789

container lid 3/4
blue

“ The view through the operating microscope allows a purely coaxial visualisation in transsphenoidal surgery: laterally located structures are concealed behind the nasal speculum. Blind tumor removal involves a higher risk of iatrogenic damage to neurovascular structures and a possible increase in tumor remnants. With the use of the MINOP TREND endoscope for transnasal procedures, these laterally located parts of the field are directly visible and therefore surgically better approachable. In the past 15 years of endoscopic transnasal surgery, the use of endoscopes has proven to be not only indispensable but rather mandatory for a safe and effective transnasal surgery in de sellar and parasellar region. ”

André Grotenhuis, Nijmegen, Netherlands



FH610R

Suction and irrigation trocar
 for 0° endoscope PE487A
 Diameter: 4.5 / 6.0 mm
 Working length: 120 mm



FH611R

Suction and irrigation trocar
 for 30° endoscope PE507A
 Diameter: 4.5 / 6.0 mm
 Working length: 120 mm



PE487A

Endoscope
 0° viewing angle,
 shaft diameter 4.0 mm



PE507A

Endoscope
 30° viewing angle,
 shaft diameter 4.0 mm



“ No other system that I have used combines as many helpful features in a single ,instrument‘. The lens cleaning is rapid and conveniently controlled with a button, instead of a pedal. The suction is effective. The ability to rotate the scope easily and quickly within the handle improves angled viewing. Overall, these features make the MINOP TREND an asset for endonasal surgery. ”

Jeremy Greenlee, Iowa City, USA

MINOP® TREND

TRansnasal ENDoscopic System

TREND – Currettes and Dissectors



FA041R-FA068R
 Working length:
 130 mm, 5 1/8"
 Total length:
 280 mm, 11"



NICOLA
FA041R
 Curette
 diam. 6.5 mm
 45° vertical
 angled long
 neck



NICOLA
FA042R
 Curette
 diam. 6.5 mm
 45° horizontal
 angled short
 neck



HARDY
FA043R
 Enucleator
 left cutting



HARDY
FA044R
 Enucleator
 right cutting



HARDY
FA045R
 Curette
 diam. 4.0 mm
 90° left angled
 long neck



HARDY
FA046R
 Curette
 diam. 4.0 mm
 90° left angled
 short neck



HARDY
FA047R
 Curette
 diam. 4.0 mm
 90° right angled
 long neck



HARDY
FA060R
 Curette
 diam. 4.0 mm
 90° right angled
 short neck

“ Difficulties in the learning curve of transsphenoidal endoscopy are often caused by handicaps of endoscope systems. The TREND endoscope clearly compensates this drawback with a human-engineered grasping part. The surgeon holds the TREND endoscope as a fine microinstrument allowing precise manipulation; the unique construction and perfect balance provide a less tiring tool for the neurosurgeon. The efficient suction/irrigation device is also incorporated within the grasping part where the valve is controlled simply with the index finger. Moreover the grasping part offers a quick connection of the endoscope to a holding arm and easy application with several navigation systems.”

Robert Reisch, Zurich, Switzerland





HARDY
FA061R
 Curette
 diam. 4.0 mm
 45° left
 horizontal angled
 short neck



HARDY
FA062R
 Curette
 diam. 4.0 mm
 45° right
 horizontal angled
 short neck



HARDY
FA063R
 Curette
 diam 6.0 mm
 90° left angled
 long neck



HARDY
FA064R
 Curette
 diam. 6.0 mm
 90° left angled
 short neck



HARDY
FA065R
 Curette
 diam. 6.0 mm
 90° right angled
 long neck



HARDY
FA066R
 Curette
 diam. 6.0 mm
 90° right angled
 short neck



**REULEN-
 LANDOLT**
FA067R
 Micro Hook
 diam. 1.7 mm



**REULEN-
 LANDOLT**
FA068R
 Dissector
 diam. 2.0 mm
 blunt

1/1







MINOP® TREND

TRansnasal ENDoscopic System

TREND – Currettes and Dissectors



						
	NICOLA	NICOLA	HARDY	HARDY	HARDY	HARDY
	FA030R	FA031R	FA032R	FA033R	FA034R	FA035R
	Curette diam. 6.5 mm 45° vertical angled, long neck	Curette diam. 6.5 mm 45° horizontal angled, short neck	Enucleator left cutting	Enucleator right cutting	Curette diam. 4.0 mm 90° angled long neck	Curette diam. 4.0 mm 90° angled short neck
	FA030R-FA040R					
	Working length: 140 mm, 5 1/2"					
	Total length: 265 mm, 10 1/2"					
	Straight design with ergonomic grasping part and semi-sharp tips					
						
	HARDY	HARDY	HARDY	LANDOLT-REULEN	LANDOLT-REULEN	
	FA036R	FA037R	FA038R	FA039R	FA040R	
	Curette diam. 4.0 mm 45° angled short neck	Curette diam. 6.0 mm 90° angled long neck	Curette diam. 6.0 mm 90° angled short neck	Micro Hook diam. 1.7 mm	Dissector diam. 2.0 mm blunt	



Deflectable TREND - Instruments



FD137R

Deflectable TREND curette

Diameter: 6 mm
 Working length: 140 mm, 5 1/2"
 Total length: 265 mm, 10 1/2"



FD138R

Deflectable TREND knife

Working length: 140 mm, 5 1/2"
 Total length: 265 mm, 10 1/2"



FD139R

Deflectable TREND dissector

Diameter: 2.1 mm
 Working length: 140 mm, 5 1/2"
 Total length: 265 mm, 10 1/2"

MINOP® TREND

TRansnasal ENDoscopic System

Nasal Specula



1/2

COTTLE

OK105R-OK108R

OK090R

with aseptic joint, set-screw,
with extra thin blades
140 mm, 5 1/2"



OK105R 1/1



OK106R 1/1



OK107R 1/1

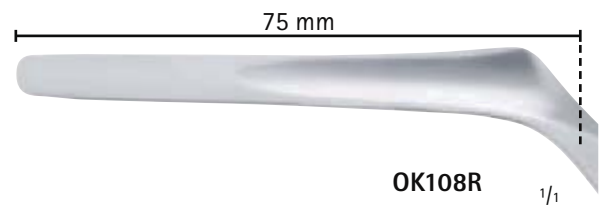

OK108R 1/1

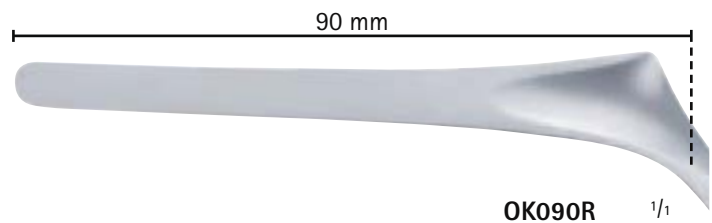

OK090R 1/1



KILLIAN

- OK081R** Fig. 1
- OK082R** Fig. 2
- OK083R** Fig. 3
- OK084R** Fig. 4

with aseptic joint
145 mm, 5 3/4"

- OK091R** Fig. 1
- OK092R** Fig. 2
- OK093R** Fig. 3
- OK094R** Fig. 4

with screw joint
140 mm, 5 1/2"

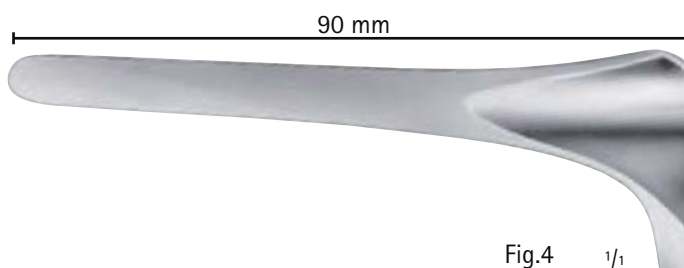
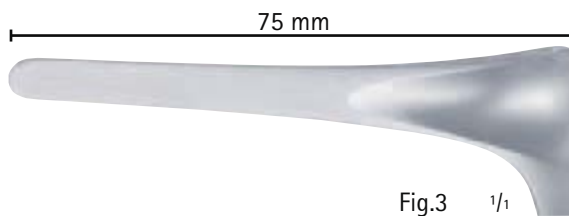
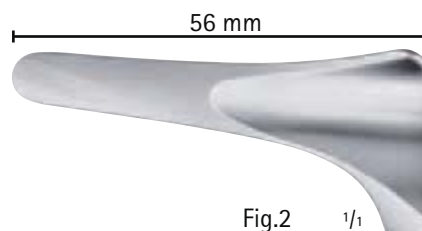
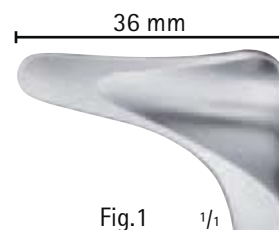

MINOP® TREND

TRansnasal ENDoscopic System

Pituitary Instruments / Sinus Punches

FA076R

Backwards cutting antrum punch,
Rotating sheath 360°,
Working length: 120 mm, 4³/₄"

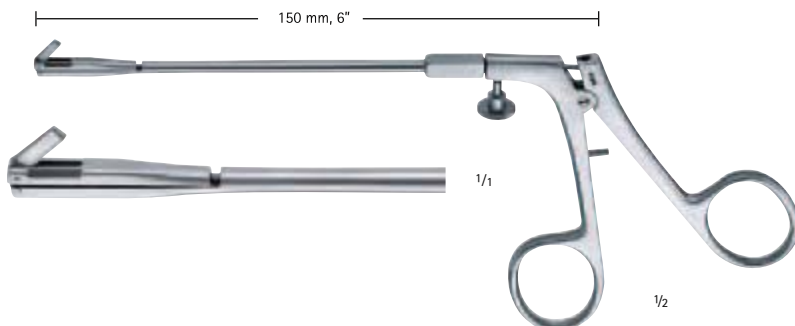

For removal of posterior nasal septum



OK602R-OK609R

Sinus Punches



		6 x 1.5 mm ^{2/1}	8 x 3 mm ^{2/1}	11.5 x 3.5 mm ^{2/1}
	straight	OK608R forward through cutting	MACKAY-GRUNEWALD OK602R forward through cutting	MACKAY-GRUNEWALD OK603R forward through cutting
	45° upwards angled	OK609R forward through cutting	MACKAY-GRUNEWALD OK606R forward through cutting	MACKAY-GRUNEWALD OK607R forward through cutting

Antrum Grasping Forceps

OK680R

jaw opening backwards,
curved downwards

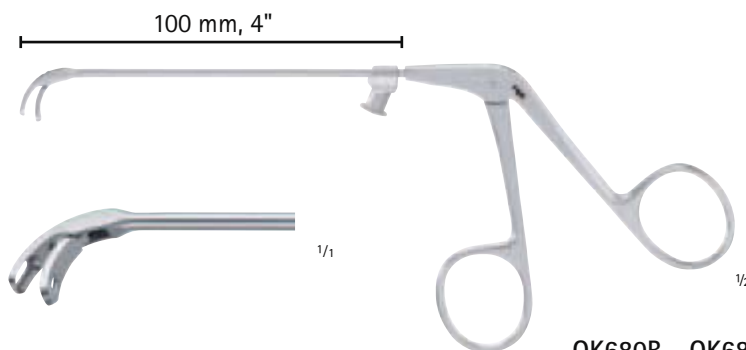

OK680R - OK683R

OK681R

jaw opening backwards,
curved upwards



OK682R

jaw opening backwards,
curved to right



OK683R

jaw opening backwards,
curved to left



OK684R

jaw opening backwards,
jaw 360° rotatable

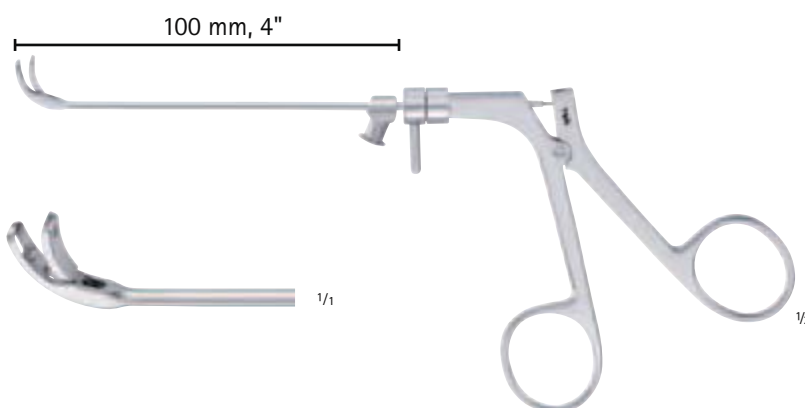

MINOP® TREND

TRansnasal ENDoscopic System

Nasal Forceps

LANDOLT

FF345R

Tumor grasping forceps,
blunt
Diam. 9.0 mm

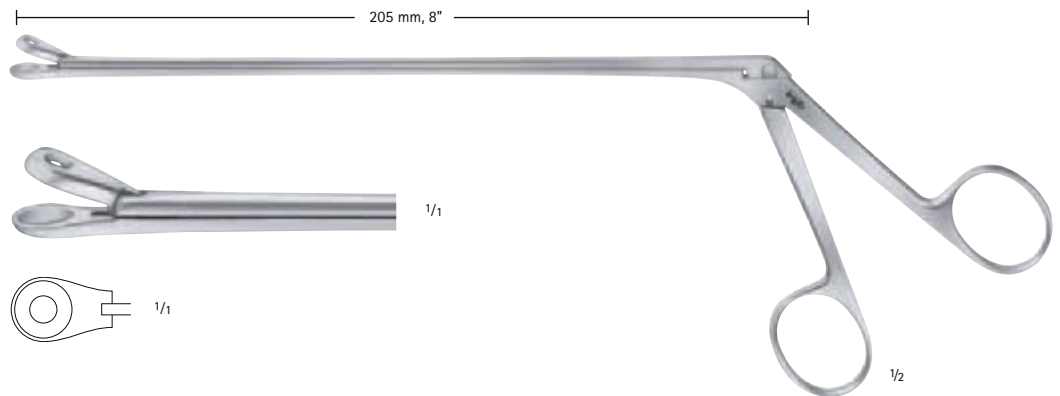

TAKAHASHI

OK525R

Rongeur, straight



Nasal Forceps

Angled positions for rongeurs

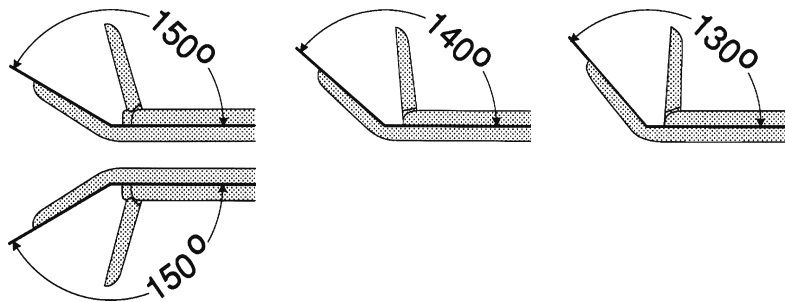

BLAKESLEY-WILDE

OK505R-OK509R

Ethmoidal forceps, straight

OK505R	3.0 mm		1/1
OK506R	3.6 mm		1/1
OK507R	4.2 mm		1/1
OK508R	4.8 mm		1/1
OK509R	5.6 mm		1/1



BLAKESLEY-WILDE

OK520R-OK522R 140°

Ethmoidal forceps, upwards curved

OK520R	3.6 mm		1/1
OK521R	4.2 mm		1/1
OK522R	4.8 mm		1/1

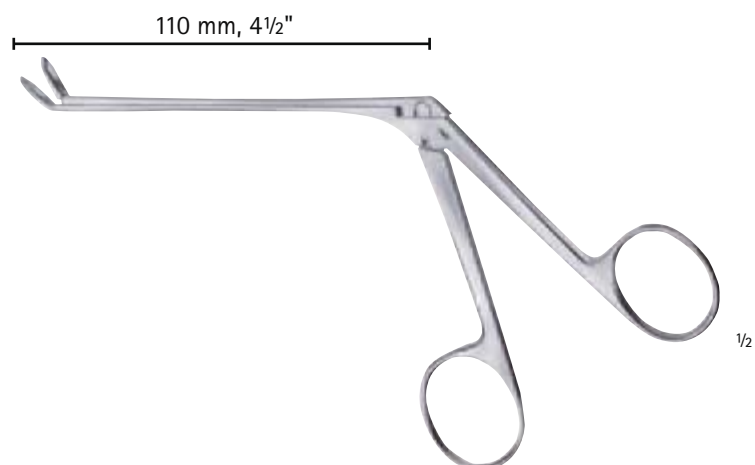

Transnasal

For more information about instruments for Functional Endoscopic Sinus Surgery (FESS), please ask your local Aesculap sales representative or see brochure no. C87511.



MINOP® TREND

TRansnasal ENDoscopic System

Nasal Scissors

OK560R - OK562R

Nasal scissors

OK560R

straight, blades serrated

OK561R

left curved, blades serrated

OK562R

right curved, blades serrated

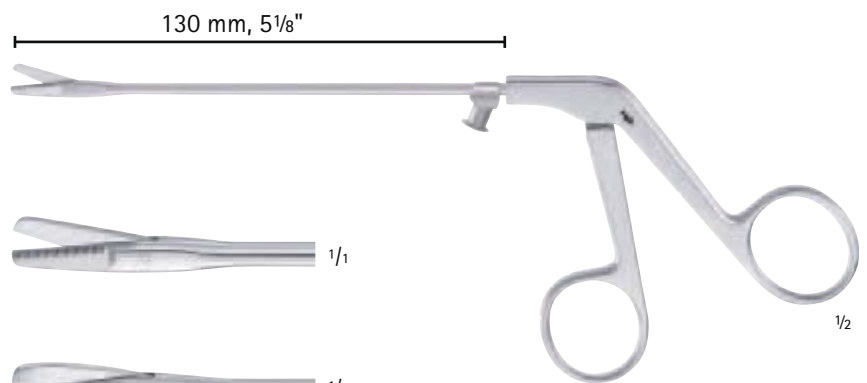

CASPAR

FD228R

Micro scissors, curved
rotatable 360°

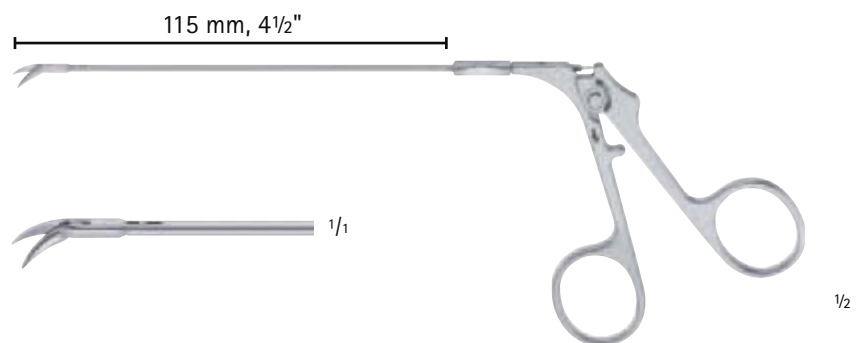

Pituitary Scissors

165 mm, 6 1/2"

FAHLBUSCH

FD220R

Micro scissors, extra delicate pattern, curved on flat, horizontal cutting



1/1



1/2

NICOLA

FD222R

Forceps, scoop-shaped, diam. 2.5 mm



1/1

FD220R-FD226R

extra delicate tubular shaft scissors and grasping instruments for pituitary & skull base surgery

YASARGIL-NICOLA

FD224R

Grasping forceps with long conical jaw



1/1

NICOLA

FD226R

Micro scissors, straight, diam. 2.5 mm



1/1

115 mm, 4 1/2"

CASPAR

FD228R

Micro scissors, curved rotatable sheath 360°

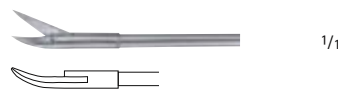

1/1



1/2



“ Essential part of the endoscopic transnasal surgery is the nasal dissection, using special pituitary instruments. Goal is the maximum exploration of the target area, but also minimally invasive nasal traumatization, thus avoiding mucosal lacerations and unnecessary bony fractures. This influences patients postoperative quality of life enormously. ”

André Grotenhuis, Nijmegen, Netherlands

MINOP® TREND

TRansnasal ENDoscopic System

Pituitary Scissors

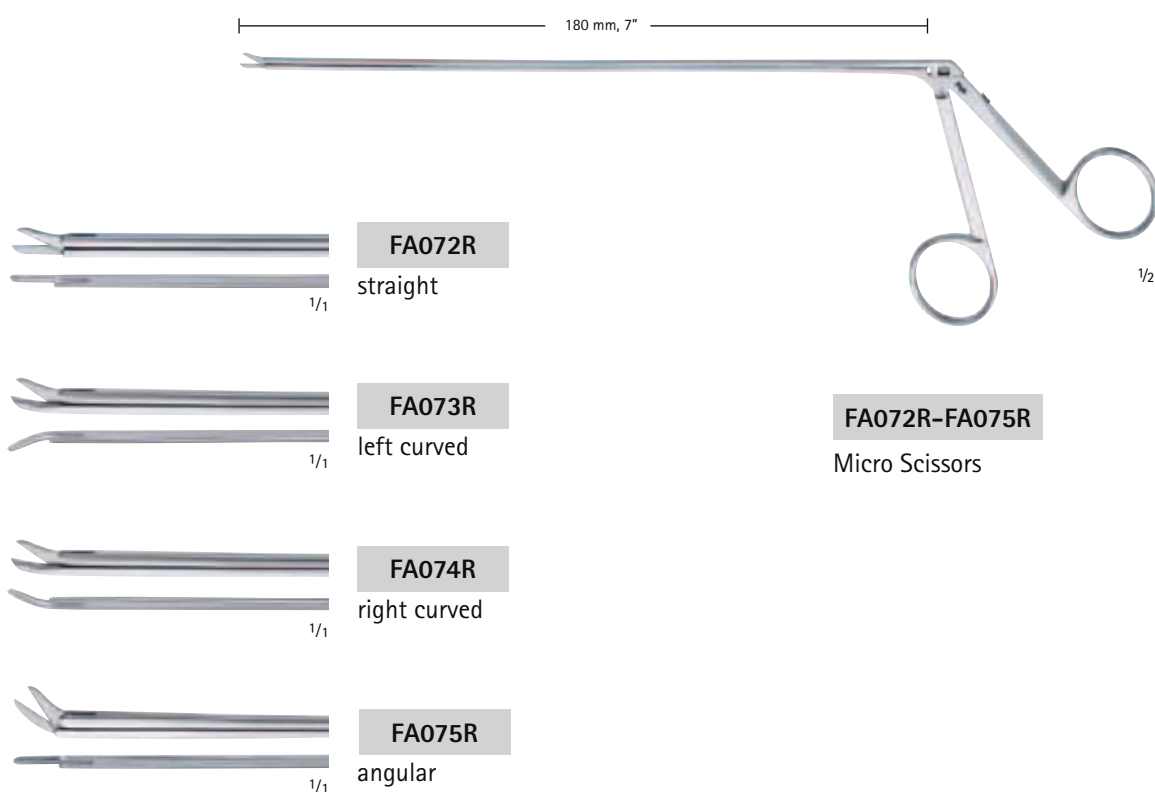

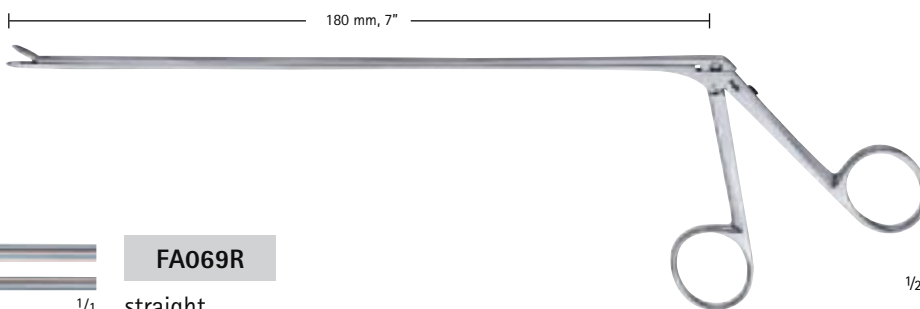

FA069R

straight



FA070R

right curved



FA071R

left curved

FA069R-FA071R
Micro Forceps

MINOP® TREND

TRansnasal ENDoscopic System

Curved Micro Suction Instruments

Suction cannulas
Curved suction instruments
FUKUSHIMA DESIGN

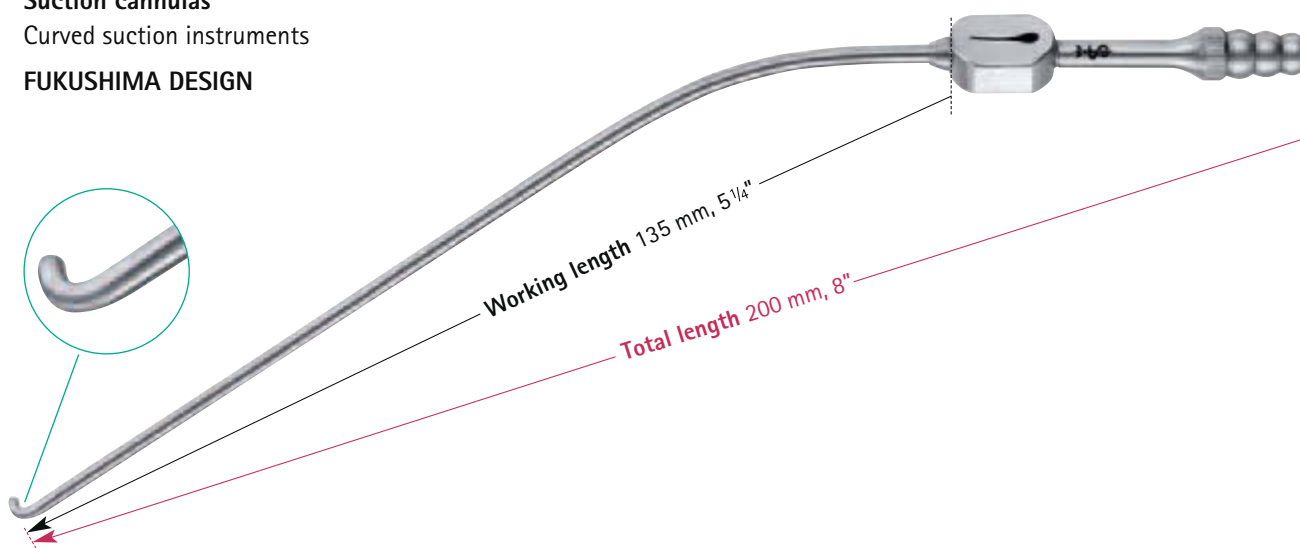

Working length	135 mm, 5 1/4"	135 mm, 5 1/4"
Total length	200 mm, 8"	200 mm, 8"
Outer diameter	2.7 mm	2.7 mm
Inner diameter	2.0 mm	2.0 mm
Angled tip	Right angled tip	Left angled tip
	GF431R	GF432R



Micro Suction Instruments

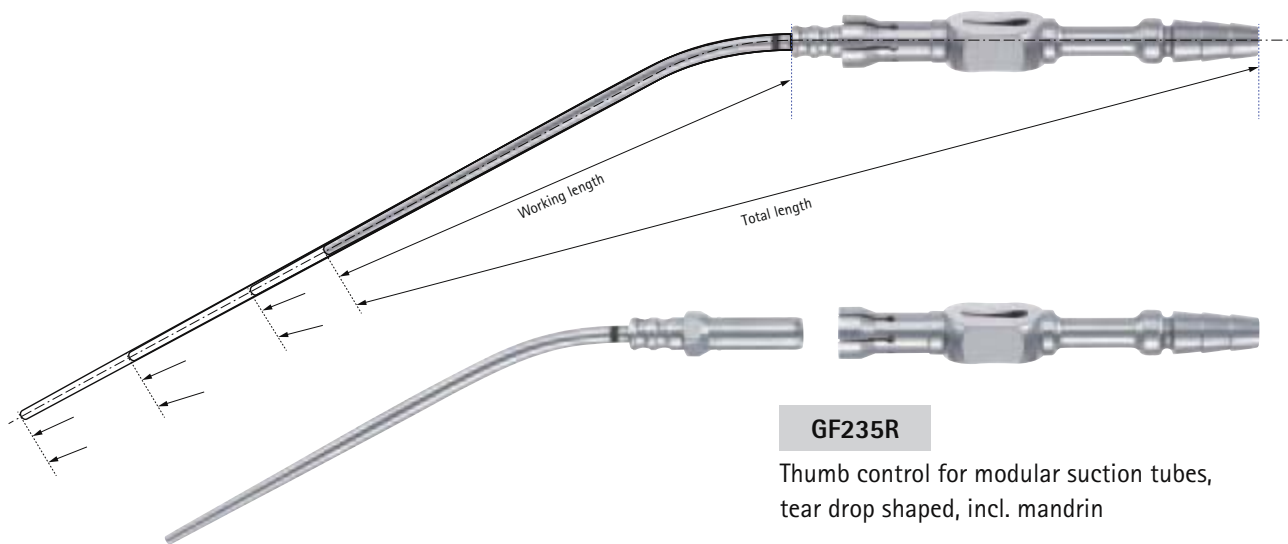

GF235R

Thumb control for modular suction tubes, tear drop shaped, incl. mandrin

		○S	○○M	○○○L	○○○○LL
Working length		100 mm	115 mm	140 mm	165 mm
Total length		185 mm	200 mm	225 mm	250 mm
Outer diameter (3Fr = 1 mm)	3 Fr. ○	GF240R	GF250R	GF260R	GF270R
	4 Fr. ○	GF241R	GF251R	GF261R	GF271R
	5 Fr. ○	GF242R	GF252R	GF262R	GF272R
	6 Fr. ○	GF243R	GF253R	GF263R	GF273R
	7 Fr. ○	GF244R	GF254R	GF264R	GF274R
	8 Fr. ○	GF245R	GF255R	GF265R	GF275R
	9 Fr. ○	GF246R	GF256R	GF266R	GF276R
	10 Fr. ○	GF247R	GF257R	GF267R	GF277R
	12 Fr. ○	GF248R	GF258R	GF268R	GF278R

MINOP® TREND

TRansnasal ENDoscopic System

Nasal Forceps

GK801R

Bipolar coagulation forceps
with slender jaws and higher
spring tension

Total length 255 mm, 10"
Working length 135 mm, 5 1/4"

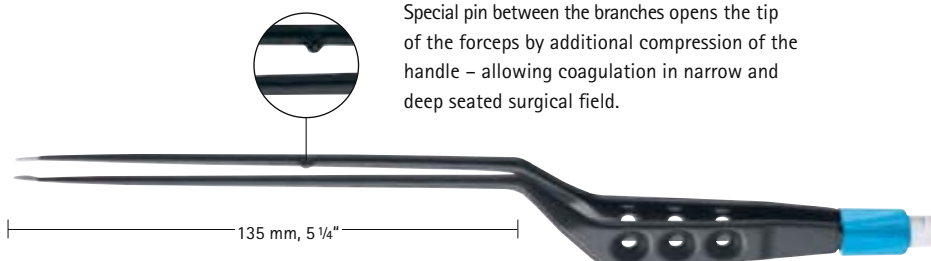

Special pin between the branches opens the tip
of the forceps by additional compression of the
handle – allowing coagulation in narrow and
deep seated surgical field.

GK800R

T-coagulation forceps
with blunt, t-shaped tips

Total length 255 mm, 10"
Working length 135 mm, 5 1/4"

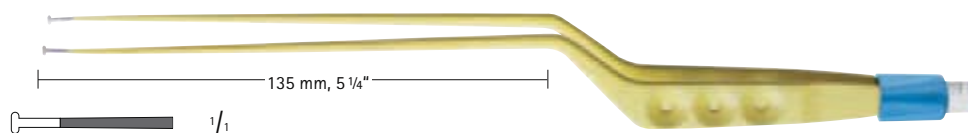

LANDOLT

GK560R

Coagulation forceps for
hypophysectomy, 90°

LANDOLT

GK580R

Coagulation forceps for
hypophysectomy, 120°

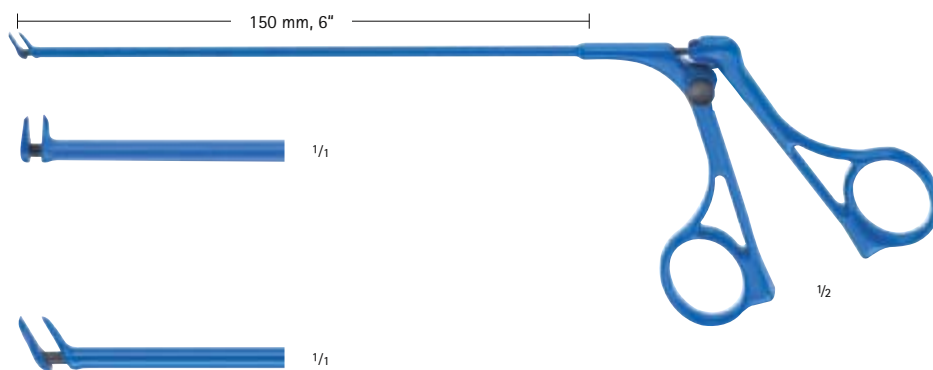

OF601R

Sickle knife, sharp tip
190 mm, 7 1/2"



BN175R

Frontal sinus ostium seeker,
double ended, curved
220 mm, 8 3/4"

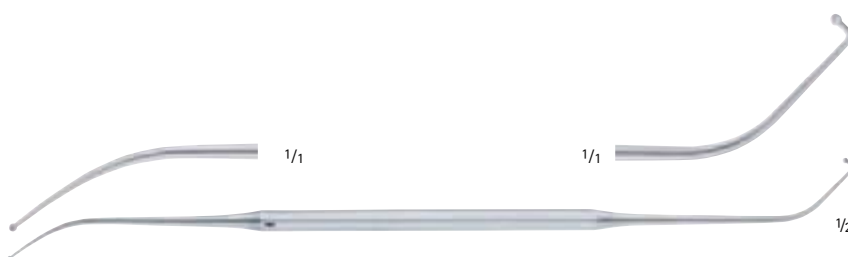

FM158R

Bayonet grasping forceps
straight tip
Total length 240 mm, 9 1/2"
Working length 120 mm, 4 3/4"



FM156R

Jaw 0.5 mm

FM157R

Jaw 0.9 mm

Bayonet micro grasping
forceps straight tip
Working length 120 mm, 4 3/4"
Total length 240 mm, 9 5/8"



MINOP® TREND

TRansnasal ENDoscopic System

KERRISON Bone Punches

Jaw position 130°, upward opening

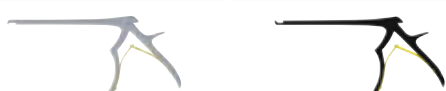

Shaft length	Width	Footplate	Detachable	Ejector	NOIR®, detachable	Ejector	Jaw opening
180 mm, 7"	1.0 mm	thin	FK906R	-	FK906B	-	8 mm
	1.5 mm	thin	FK923R	-	FK923B	-	9 mm
	2.0 mm	thin	FK907R	✓	FK907B	✓	9 mm
	2.5 mm	thin	FK924R	✓	FK924B	✓	10 mm
	3.0 mm	thin	FK908R	✓	FK908B	✓	10 mm
	4.0 mm	thin	FK909R	✓	FK909B	✓	12 mm

Jaw position 130°, downward opening



Shaft length	Width	Footplate	Detachable	Ejector	Jaw opening
180 mm, 7"	1.0 mm	thin	FK936R	-	8 mm
	2.0 mm	thin	FK937R	✓	9 mm
	3.0 mm	thin	FK938R	✓	10 mm



KERRISON Bayonet Bone Punches

Jaw position 130°, upward opening

Length	Width	Working length	Article No.	Jaw width
240 mm, 7"	2.0 mm	170 mm	FF496R	10 mm
	3.0 mm	170 mm	FF497R	10 mm
	4.0 mm	170 mm	FF498R	10 mm
	5.0 mm	170 mm	FF499R	10 mm



For more information about MINOP® TREND please see our „Practical Atlas“ C26402.



Aesculap Neurosurgery

Holding Devices

M-TRAC – Mechanical Holding Arm

FF168R

M-TRAC – Flexible holding device with mechanical fixation

- Assembly: flexible holding arm with integrated fixation bar
- Total length: 107 cm
- Length of fixation bar: 46 cm
- Diameter of fixation bar: 20 mm
- Total weight: 0,7 kg
- Holding force: 4 kg
- Easy mechanical fixation by clamping handle
- Small, flexible joints for fine positioning
- Autoclavable 134°C, 5 minutes
- Full range of accessories/adapters for connecting Aesculap endoscopes, trocars and instruments
- Holding Arm fits into regular Standard 1/1 Container



FF280R

Flexible fixation element with ball joint suitable for RT040R and FF168R



RT090R

Flexible fixation element with sprocket suitable for RT040R and FF168R



FF151R

Rigid fixation element suitable for RT040R and FF168R



UNITRAC® – Pneumatic Holding Arm

RT040R

UNITRAC®

- Single handed use
- Fast sterile set-up in the OR
- Universal retraction and holding system with special accessories for neuroendoscopy
- Simple to assemble onto the OR table railing
- Integrated safety systems prevent collapse of holding arm if OR compressed air supply is interrupted
- Direct connection to OR compressed air supply
- Diameter of fixation bar: 20 mm
- To be used with JG901



JG901

Sterile drape for coverage of the Unitrac® arms, single-use product, package of 50 pcs.



RT020R

Quick connect adapter for use with sterile drape JG901 allows the change of instruments after draping with JG901



RT043R

CO₂ cartridge adapter For use of Unitrac independent from compressed air sources



RT044SU

Unitrac CO₂ cartridge pack of 10 pcs Single use product



“ Bimanual, two-handed dissection forms the foundation of microneurosurgery and is also an essential precondition for transsphenoidal endoneurosurgery. For this reason, the TREND endoscope can be easily fixed in a special holding arm: the endoscope placed through nostril does not disturb surgical dissection, especially by using biportal – binostril approaches. The pneumatic and mechanical devices can be also used effectively in transcranial endoscope-controlled and intraventricular pure endoscopic neurosurgery. ”

Nikolai Hopf, Stuttgart, Germany

Aesculap Neurosurgery

Holding Devices

Adapters for UNITRAC® and M-TRAC

RT046P

Universal holder
for endoscopes and trocars with
diam. 3.0–7.5 mm, consisting of:
RT081R and RT055P



RT099R

Adapter
for fixation of MINOP® TREND
handle, FH615



RT081R

Adapter
for universal insert RT055P



RT079R

Adapter
for fixation of angled
endoscopes PE486A, PE506A,
PE526A



RT055P

Universal insert (Spare Part)
for endoscopes and trocars with
diam. 3.0–7.5 mm



RT068R

Adapter
for fixation of MINOP® InVent
trocar, FH620R



RT079205

Silicone bit
for RT079R





	MINOP® FF397R FF398R FF399R	Paediscopes PA010A	MINOP® InVent FH620R	Angled scopes PE486A PE506A PE526A	MINOP® TREND FH615	MINOP® TR FH601R
RT046P	●	●		●		●
RT099R					●	
RT079R				●		
RT068R			●			



Holding Devices

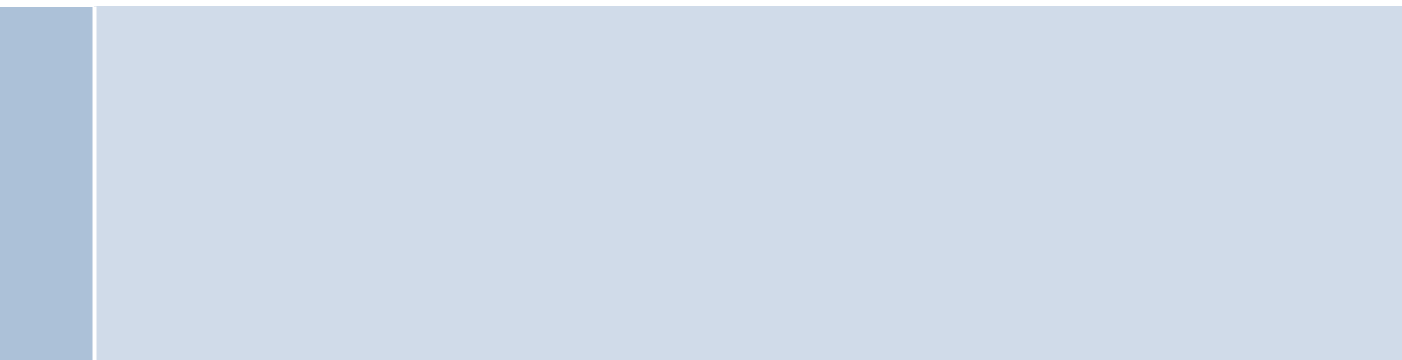

Aesculap Neurosurgery

Holding Devices

Neuropilot® – Fine-positioning for UNITRAC® and M-TRAC

NeuroPilot® for IntraVentricular and Endoscope-Assisted indications with all Aesculap neuroendoscopes. NeuroPilot® is a new, unique steering device for neuroendoscopes. After positioning the neuroendoscope in situ, finest corrections or adjustments are necessary, to receive the optimal endoscopic image. With traditional holding devices, only rough positioning is possible; a precise and fine steering of the neuroendoscope can be compromised. NeuroPilot® offers a number of unique advantages:

- Proper fixation of the neuroendoscope in the NeuroPilot® and the holding device
- Precise steering of the neuroendoscope by three screws in the three-dimensional space
- Accurate manoeuvring of the neuroendoscope by defined movements in the sub-millimeter area

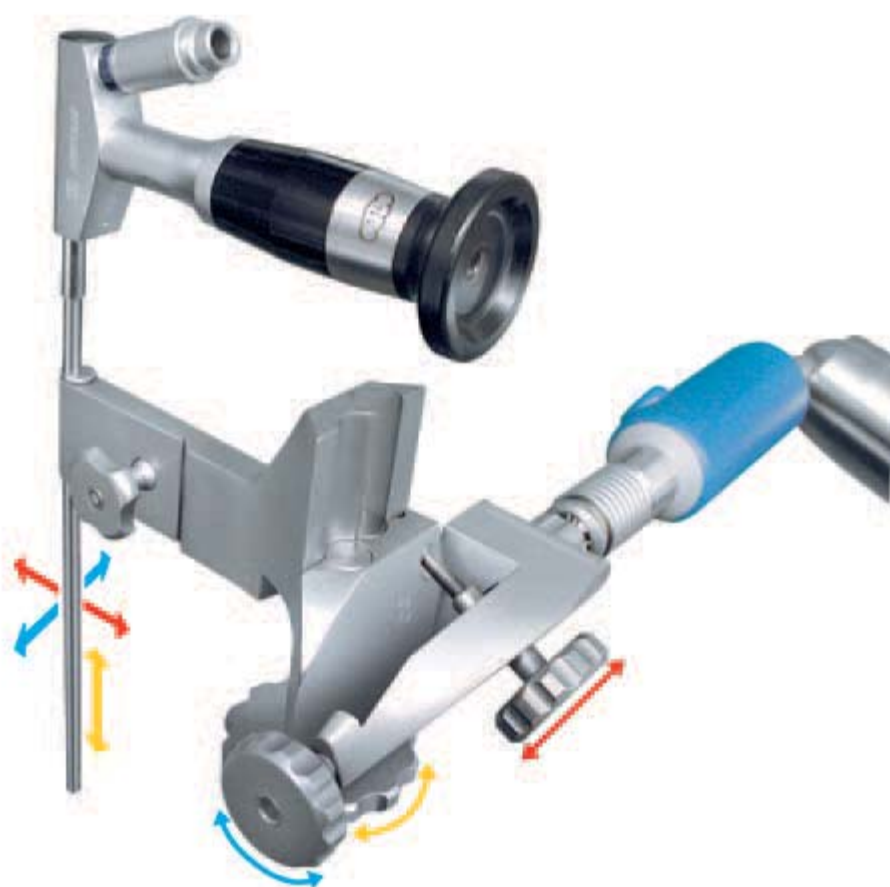

“ In pure intraventricular neuroendoscopy, a micro-steering device can be extremely useful. If the precision and adjustment of a holding arm is not enough, the Neuropilot closes this gap. Additionally, in cases where both hands are needed for instrumentation the Neuropilot is of great help. The Aesculap Neuropilot is the only system on the market providing finest correction of your endoscope in a three-dimensional space inside the ventricular compartments.”

Peter Nakaji, Phoenix, USA



RT060R

NeuroPilot®
for intraventricular and
endoscope-assisted indications

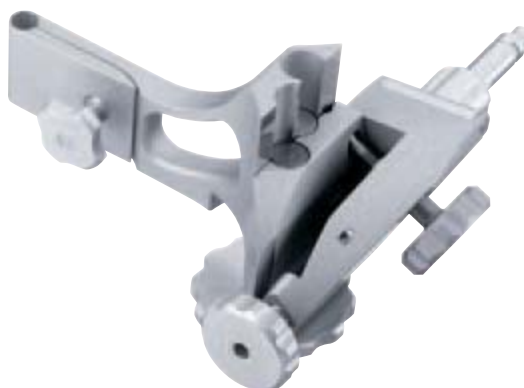

RT061R

Insert for angled endoscopes
PE486A - PE526A with diam. 4.0 mm



RT065R

Insert for MINOP® trocar FF399R
with diam. 6.0 mm



RT063R

Insert for MINOP® trocar FF397R
with diam. 3.2 mm



RT066R

Insert for PaediScope® PF010A
with diam. 3.0 mm



RT064R

Insert for MINOP® trocar FF398R
with diam. 4.6 mm



Aesculap Neurosurgery

Holding Devices

Neuropilot® – Fine-positioning for UNITRAC® and M-TRAC

	MINOP® FF397R	MINOP® FF398R	MINOP® FF399R	Paediscopes PA010A	Angled scopes PE486A PE506A PE526A	MINOP® TR FH601R
RT060R	●	●	●	●	●	●
RT061R					●	
RT063P	●					
RT064P						●
RT065P		●				
RT066P			●	●		

Operating Manuals



Aesculap® MINOP®
 Intraventricular Neuroendoscopy: A Practical Atlas
 Mark M. Souweidane, M.D., F.A.C.S, F.A.A.P.
 C29202



Aesculap® MINOP® TEAM
 Transcranial Endoscope-Assisted Microneurosurgery: A Practical Atlas
 Robert Reisch, M.D., Ph.D.
 C29802



Aesculap® MINOP® TREND
 TRansnasal NeuroENDoscopy: A Practical Atlas
 Robert Reisch, M.D., Ph.D.
 C26402

Aesculap Neuroendoscopy App

D-NET1005

App Store > Search > B. Braun AG

B. BRAUN
SHARING EXPERTISE

Helsinki Microneurosurgery App

D-NET1003

App Store > Search > B. Braun AG

B. BRAUN
SHARING EXPERTISE

Aesculap Neurosurgery

Visual Equipment Examples for Neuroendoscopy

Full HD Camera, Xenon Light Source, Documentation System and Touch Screen



“ Recently, the intraoperative use of full high definition (HD) image quality offers a new area in endoscopic neurosurgery with an increased range of indications in minimally invasive neurosurgery. The image quality of the full-HD system is markedly superior to that of a standard one- or three-chip camera unit providing a five times higher optical resolution. This superior quality is particularly important in delicate situations, namely the differentiation of subtle structures and in the case of blurred scope vision. A recording system is also an important part of the equipment for documentation of the procedure and is useful for scientific evaluation and teaching purposes. An ideal solution is a digital video system with user friendly and rapid recording, e.g. with a touch screen. ”

Nikolai Hopf, Stuttgart, Germany

Full HD CMOS Camera, LED Light Source and Flat Screen

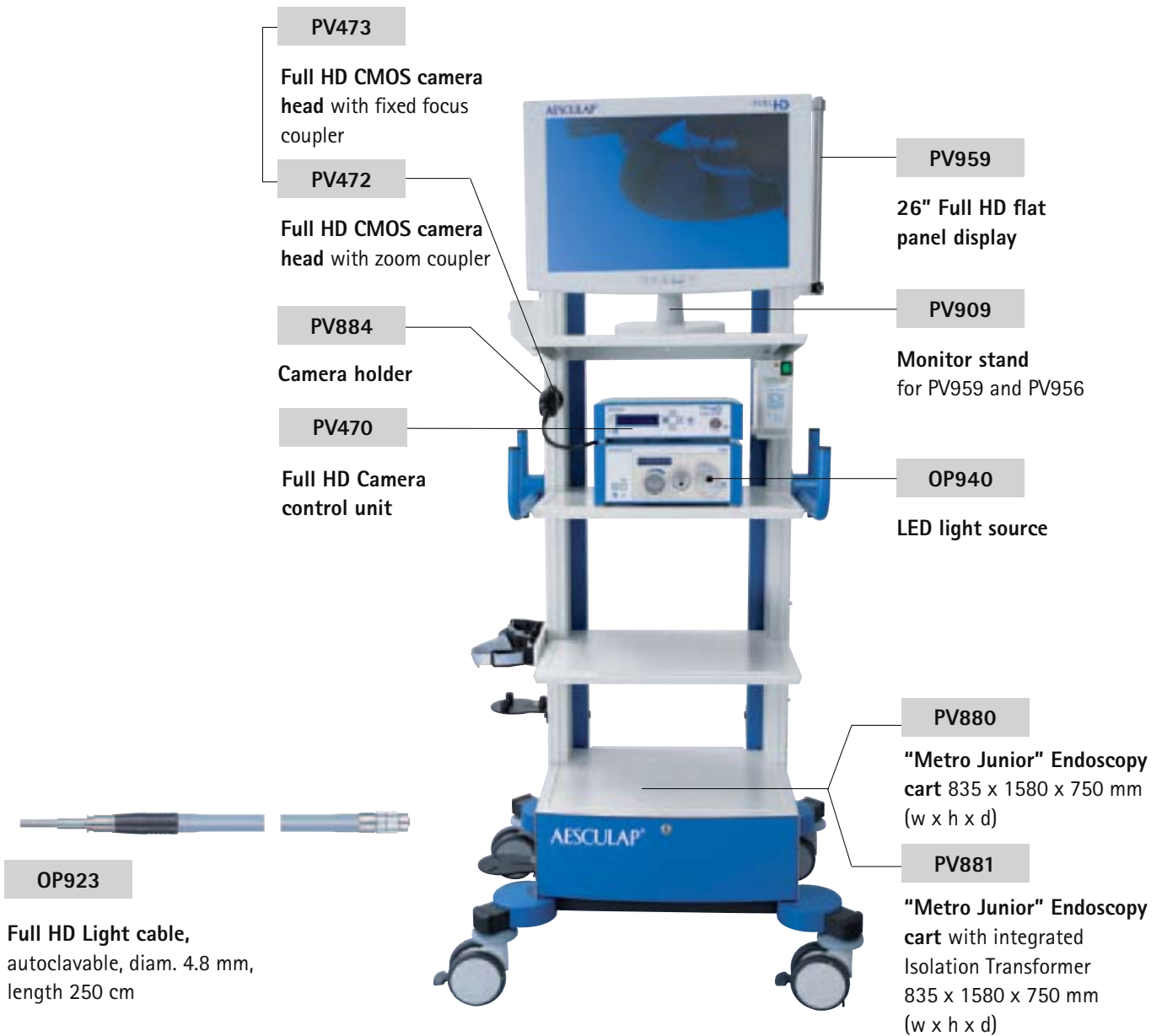

For more information see brochure C46702



Aesculap Neurosurgery Power Systems

microspeed® uni – Electric High Speed Motor System

System components:



GD670 microspeed uni control unit



GD675 microspeed uni XS high speed motor
for Hi-Line XS and Hi-Line XXS handpieces



GD685 microspeed uni perforator driver
with Hudson chuck



GD672 motor cable



GD668 foot control – single pedal



HiLAN® XS – Pneumatic High Speed Motor System

System components:



GA740R HiLAN XS high speed motor
for Hi-Line XS and Hi-Line XXS handpieces



GA742R HiLAN perforator driver
with Hudson chuck



GA521 Foot Pedal



GA513R Motor hose (3 m)

GA464R Supply hose (3 m)
wall connection Aesculap Dräger

GA468R Supply hose (3 m)
wall connection Schrader

GA461R Supply hose (3 m)
wall connection DIN

For more information about microspeed uni equipment and accessories, please ask your local Aesculap sales representative or see brochure no. 028302



For more information about HiLAN XS equipment and accessories, please ask your local Aesculap sales representative or see brochure no. 026002.



Aesculap Neurosurgery

Power Systems

Hi-Line XS Handpieces and Tools



GB740R

Craniotome and multi-function handpiece



Pediatric

Standard

Long

Holding sleeve for reaming



▲ **GB745R**

Drill depth guard for controlled pilot drilling
Drilling depth: 2-8 mm adjustable



▲ **GB744R**



I **GB741R** II **GB742R** III **GB743R**

Fixed dura guards



Twin-cut burrs

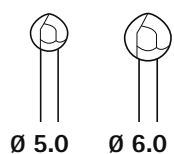

Ø 5.0 Ø 6.0

▲ GE396R GE397R

Diamond burrs standard

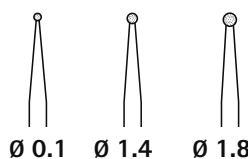

Ø 0.1 Ø 1.4 Ø 1.8

GE381R GE382R GE382R

Diamond burrs coarse

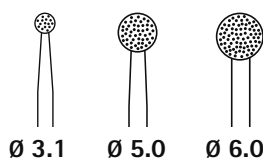

Ø 3.1 Ø 5.0 Ø 6.0

GE394R GE398R GE399R

extra coarse

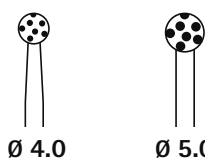

Ø 4.0 Ø 5.0

GE386SU ② GE387SU ②

Twist drills

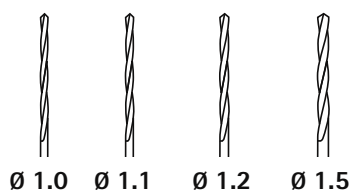

Ø 1.0 Ø 1.1 Ø 1.2 Ø 1.5

▲ GE390R GE391R GE389R GE395R

Pin cutter

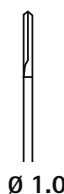

Ø 1.0

GE392R



Steerable dura guards

I II III
GB746R GB747R GB748R

Craniotome cutters

spiral straight

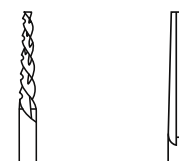

I	GE420R	GE429SU ②
II	GE520R	GE529SU ②
III	GE620R	GE629SU ②

Aesculap Neurosurgery

Power Systems

Hi-Line XS Handpieces and Tools - Standard

The proven user-friendly ring coding system allows simple and clear identification of handpiece and associated burrs.



Rosen burrs

	Ø	1.0 mm	1.4 mm	1.8 mm	2.3 mm	2.7 mm	3.1 mm	4.0 mm	5.0 mm	6.0 mm	
I		GE401R	GE402R	GE403R	GE404R	GE405R	GE406R	GE407R	GE408R	GE409R	
II		GE501R	GE502R	GE503R	GE504R	GE505R	GE506R	GE507R	GE508R	GE509R	
III				GE603R	GE604R	GE605R	GE606R	GE607R	GE608R	GE609R	

Rosen burrs - Long neck

	Ø	0.6 mm	0.8 mm	1.0 mm	1.4 mm	1.8 mm	1.8 mm	2.3 mm	2.7 mm	
I	⊗	GE469SU	GE470SU	GE471SU			GE473SU		GE475SU	
II					GE572R	GE573R		GE574R		
III										

Diamond burrs

	Ø	1.0 mm	1.4 mm	1.8 mm	2.3 mm	2.7 mm	3.1 mm	4.0 mm	5.0 mm	6.0 mm	
I		GE411R	GE412R	GE413R	GE414R	GE415R	GE416R	GE417R	GE418R	GE419R	
II		GE511R	GE512R	GE513R	GE514R	GE515R	GE516R	GE517R	GE518R	GE519R	
III				GE613R	GE614R	GE615R	GE616R	GE617R	GE618R	GE619R	

Aesculap Neurosurgery

Power Systems

Hi-Line XS Handpieces and Tools

Diamond burrs - Long neck

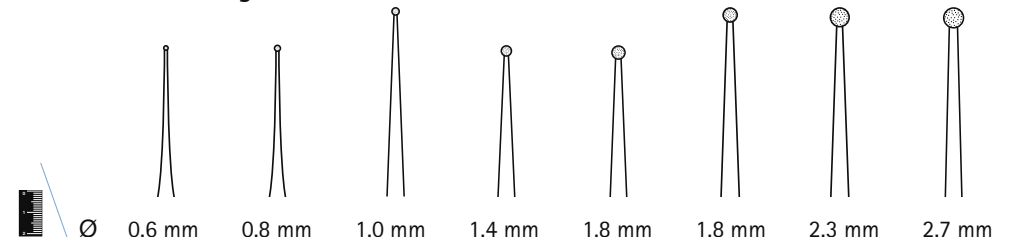

	Ø	0.6 mm	0.8 mm	1.0 mm	1.4 mm	1.8 mm	1.8 mm	2.3 mm	2.7 mm
I	⊗	GE459SU	GE460SU	GE461SU			GE463SU	GE464SU	GE465SU
II					GE562R	GE563R			

Diamond burrs coarse

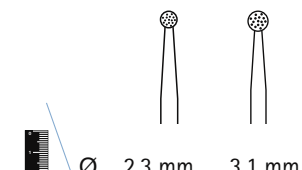

	Ø	2.3 mm	3.1 mm
I		GE424R	GE425R
II		GE524R	GE525R
III		GE624R	GE625R

Diamond burrs extra coarse

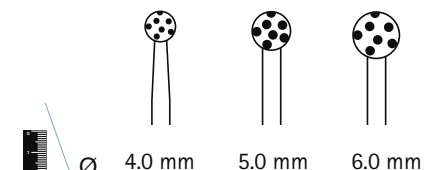

	Ø	4.0 mm	5.0 mm	6.0 mm
I	⊗	GE456SU	GE457SU	
II	⊗	GE556SU	GE557SU	GE558SU
III	⊗	GE656SU	GE657SU	GE658SU

Acorn burrs

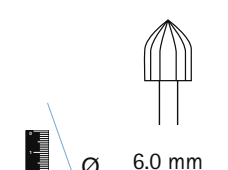

	Ø	6.0 mm
I		GE437R
II		GE537R

Neuro cutters

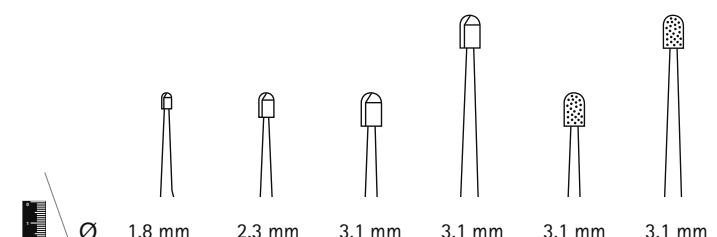

	Ø	1.8 mm	2.3 mm	3.1 mm	3.1 mm	3.1 mm	3.1 mm
I				GE435R			
II		GE531R	GE534R	GE535R	GE553R		GE555R
III		GE631R	GE634R	GE635R	GE653R	GE654R	GE655R

Lindemann

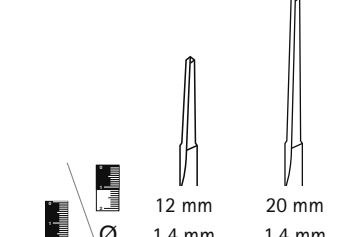

	Ø	12 mm	20 mm
		1.4 mm	1.4 mm
II		GE522R	GE523R

Pin cutter

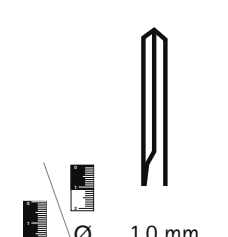

	Ø	1.0 mm
II		GE521R



Barrel burrs
soft cut

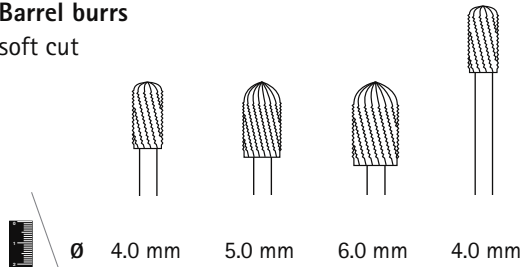

II	GE548R	GE549R	GE550R	
III	GE648R	GE649R	GE650R	GE645R

Barrel burrs
standard

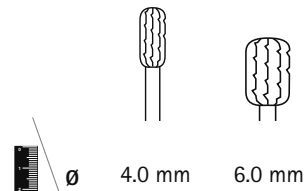

II	GE544R	GE546R
III	GE644R	GE646R

Cone burrs

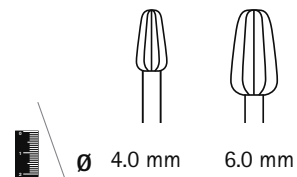

II	GE540R	GE542R

Reverse taper burr coarse diamond

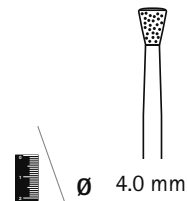

II	GE539R
III	GE639R

Oval burr

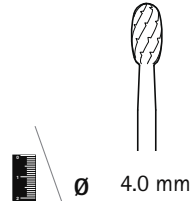

II	GE536R

Rosen burrs - Tungsten carbide

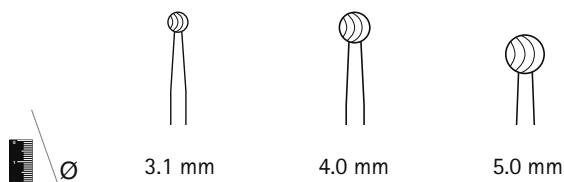

I	⊗	GE406TC-SU	GE407TC-SU	GE408TC-SU
II	⊗		GE507TC-SU	GE508TC-SU
III	⊗		GE607TC-SU	GE608TC-SU

Neuro cutter - Tungsten carbide

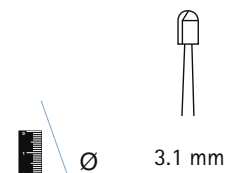

I	⊗	GE435TC-SU
II	⊗	GE535TC-SU
III	⊗	GE635TC-SU

Aesculap Neurosurgery

Power Systems

Hi-Line XS Handpieces and Tools – Extra Long

The proven user-friendly ring coding system allows simple and clear identification of handpiece and associated burrs.



Rosen burrs

Ø	2.3 mm	3.1 mm	4.0 mm	5.0 mm	6.0 mm
XLI	GE704R	GE706R	GE707R	GE708R	GE709R

Diamond burrs

Ø	2.3 mm	3.1 mm	4.0 mm	5.0 mm	6.0 mm
XLI	GE714R	GE716R	GE717R	GE718R	GE719R

Neuro cutters

Ø
3.1 mm
XLI
GE702R

Barrel burrs soft cut

Ø	4.0 mm	5.0 mm	6.0 mm
XLI	GE711R	GE729R	GE712R

Twist drills

Ø
1.5 mm
XLI
GE700SU

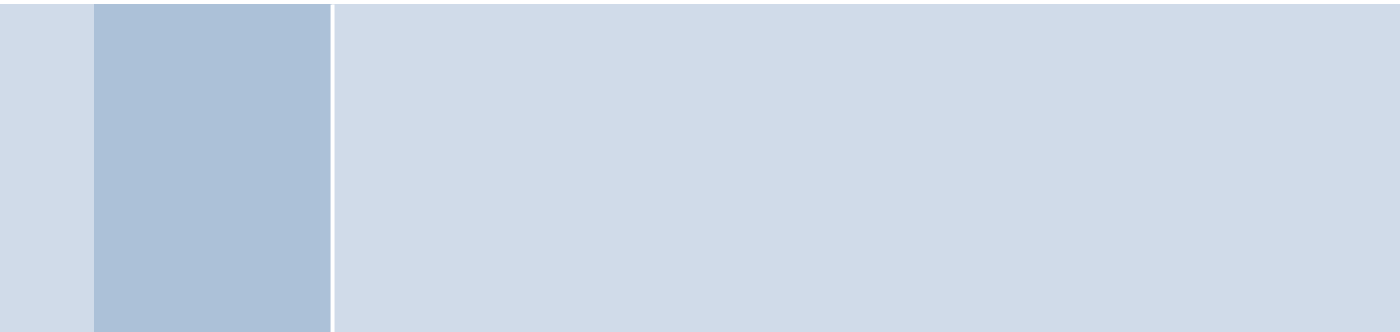
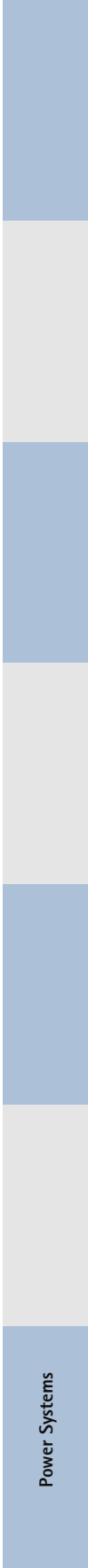
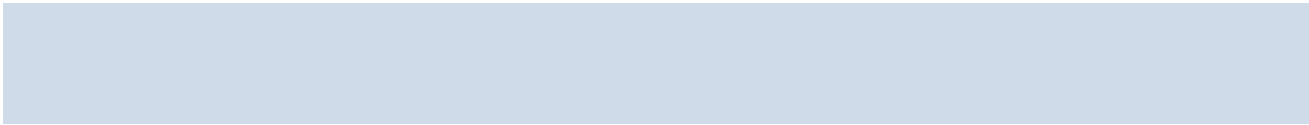

Aesculap Neurosurgery





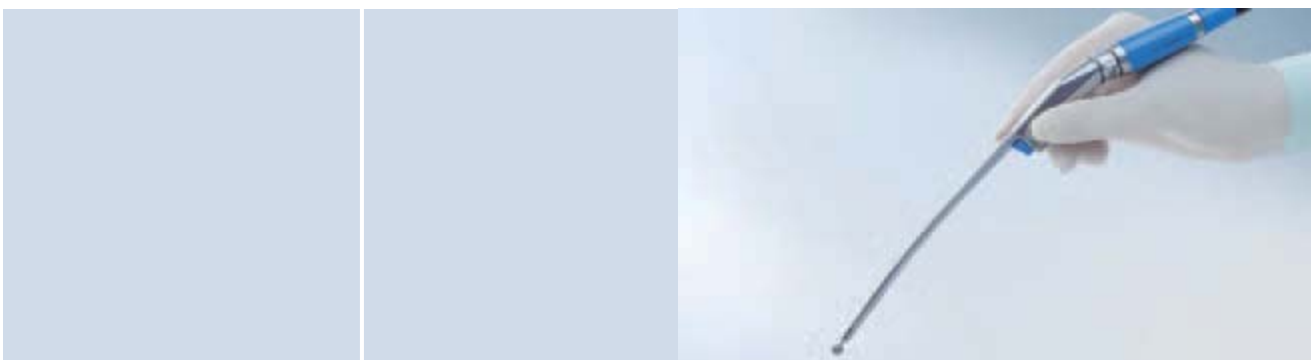

Power Systems

Hi-Line XXS – Handpiece for Minimally Invasive Procedures







- Straight and curved handpiece shafts
- The curved handpiece shafts can be rotated in 8 different positions
- Proven ring-coding system correctly matches handpiece shafts to the associated burs
- Completely keyless operation









Rosen burrs

			
		3.0 mm	4.0 mm
II		GE804SU	GE805SU
III		GE834SU	GE835SU









Diamond burrs, coarse

				
		3.0 mm	4.0 mm	5.0 mm
II		GE816SU	GE817SU	GE818SU
III		GE846SU	GE847SU	GE848SU

Neuro cutter

			
		2.0 mm	3.0 mm
II		GE802SU	GE803SU
III		GE832SU	GE833SU

Neuro cutter, coarse diamond

					
		2.0 mm	3.0 mm	4.0 mm	5.0 mm
II		GE812SU	GE813SU	GE814SU	GE815SU
III		GE842SU	GE843SU	GE844SU	GE845SU

For more information about Hi-Line XXS equipment and accessories, please ask your local Aesculap sales representative or see brochure no. 046502



Aesculap Neurosurgery

Power Systems

Accessories

Spray nozzles

Spray nozzle	Handpiece	Length of handpiece
GB767SU	Hi-Line XS	GB740R
GB761SU		I
GB762SU		II
GB763SU		III
GB764SU		XLI
GB796SU	Hi-Line XXS	II
GB797SU		III

Maintenance



GB600

Sterilit® Power Systems Oil Spray



GB600820

Spray Adaptor
for HiLAN, HiLAN XS and
Hi-Line (XS, XXS) handpieces



GB600870

Spray Adaptor
for microspred uni XS



For more information about Aesculap Power Systems and accessories, please ask your local Aesculap sales representative or see brochure no. 022702



For more information about Burrs & Blades for Aesculap Power Systems please ask your local Aesculap sales representative or see brochure no. 017599

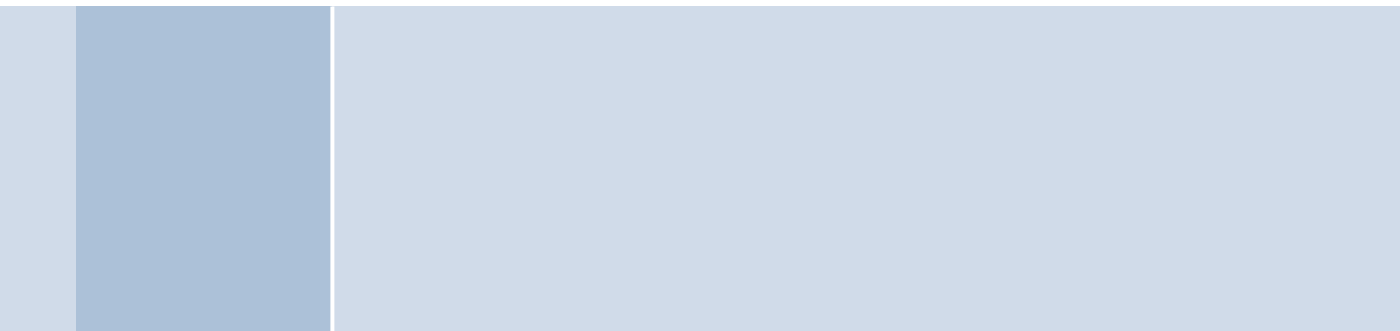
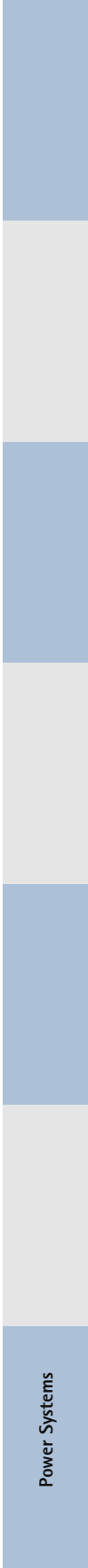
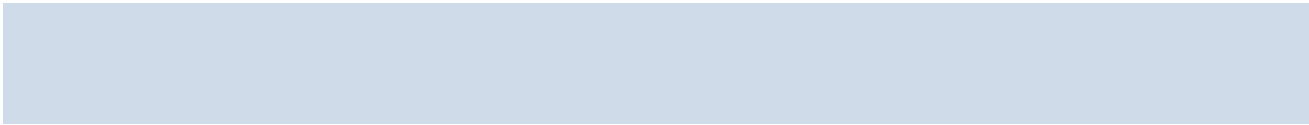

Aesculap Academy

Neuroendoscopy Courses

Horizons of Knowledge. Competence to Master the Future.



www.aesculap-neuro.com or
www.aesculap-academy.com

Innovative developments in the field of medical technology, sophisticated new treatment methods, increasingly more stringent requirements for hospital and quality management and, last but not least, a healthy interest in acquiring new knowledge have given rise to an enormous and ever-increasing demand for further and advanced training.

The Aesculap Academy enjoys a world-wide reputation as a leading forum for medical training and answers the demands of physicians and medical staff in OR, anaesthesia, ward, outpatient care and hospital management. The course program comprises a wide range of hands-on workshops, management seminars and international symposia.

Aesculap Academy courses are of premium quality and are accredited by the respective medical societies and international medical organizations. A scientific advisory board guarantees the perfect selection of speakers and topics.

All of our courses are conducted by pioneering neurosurgeons who will address the theoretical knowledge of neuroendoscopy, cranial endoscopic anatomy, and clinical applications of neuroendoscopy. Each course includes extensive hands-on sessions or possibly live surgeries. Course attendees will benefit from discussions and analysis of real cases together with expert colleagues from all over the world. The training facilities of the Aesculap Academy in Berlin and Tuttlingen are traditional and spectacular locations for "sharing expertise".

Competence to master the future – keep yourself fit for the future and ask for the latest course programme offerings, e.g.

- Intracranial Neuroendoscopy Course
- Advanced Neuroendoscopy Course
- Master Course Intercranial Neuroendoscopy

Visit our website and register for one of the next neuroendoscopy courses – www.aesculap-neuro.com or www.aesculap-academy.com or contact your local B. Braun Aesculap representative.

“Pre-requisites of intracranial neuroendoscopy are valuable and user-friendly endoscopic equipment. However, despite of availability of dedicated systems, the endoscopic technique is not in routine use everywhere and neurosurgeons are often hesitant to use it. The cause of the aversion is often the steep learning curve. The goal of our Neuroendoscopy Courses is to facilitate the initial steps, thus giving a comprehensive overview in contemporary endoscopic techniques, including intraventricular, transcranial and transnasal applications. Didactic lectures by international experts give the necessary theoretical basis. Extensive hands-on laboratory allow basic anatomical studies and offer practical experience with endoscopes. Illustrative live surgeries show clinical application, giving advantageous tips in the every-day application of neuroendoscopy.”



Program



Intracranial Neuroendoscopy

a basic hands-on training course for endoscopic neurosurgery

The objective of the course "Intracranial Neuroendoscopy" is to offer a comprehensive overview on endoscopic techniques in intracranial neurosurgery. Didactic lectures, extensive hands-on laboratory and illustrative cases are especially designed for newcomers in the field of neuroendoscopy, giving excellent theoretical and practical basis. Manuals and digital documentation of your own laboratory exercise provide an additional positive impact on your learning.

Advanced Intracranial Neuroendoscopy

a comprehensive hands-on course on minimally invasive and endoscopic neurosurgery

"Advanced Intracranial Neuroendoscopy" is designed for neurosurgeons with basic experience in neuroendoscopic techniques. The didactic lectures address especially the preoperative surgical planning as well as distinguished endoscopic techniques for cranial neurosurgery. Extended hands-on dissections and illustrative live surgeries demonstrate clinical applications in the daily routine offering important tips and tricks as well as valuable instructions for everyday use. The course is offered in two complementary parts. However, please note, that both parts can be booked separately as well as in combination.

Part I (Transcranial Endoscope-assisted Neurosurgery) concentrates on minimally invasive transcranial keyhole approaches and endoscope-assisted techniques dealing in a comprehensive way with the supraorbital, subtemporal and retrosigmoidal exposure.

Part II (Transcranial Endoscopic Skull Base) deals with endoscopic techniques to treat sellar and parasellar lesions via the transsphenoidal route. Special interest will be given to extended skull base surgery.

Master Course Intracranial Neuroendoscopy

a clinical observer course on minimally invasive and endoscopic neurosurgery

The "Master Course Intracranial Neuroendoscopy" offers a clinically oriented comprehensive overview on contemporary techniques in cranial endoscopic neurosurgery. Dedicated lectures, extensive case discussions and live surgeries will offer important tips and tricks providing valuable instructions for your everyday use. This event is a perfect and well recommended adjunct to the hands-on courses on "Intracranial Neuroendoscopy" and "Advanced Intracranial Neuroendoscopy" in Berlin and Tuttlingen. In addition, you will have the opportunity to look behind the scenes of the headquarters and manufacturing plant of B. Braun Aesculap in Tuttlingen. Forming aneurysm clips by yourself, experiencing how micro instruments are manually fabricated and visiting the famous Surgery Museum Asclepius are impressive parts of the course.



André Grotenhuis
Nijmegen, Netherlands



Nikolai Hopf
Stuttgart, Germany



Peter Nakaji
Phoenix, USA



Robert Reisch
Zurich, Switzerland



Mark Souweidane
New York, USA

Aesculap Neurosurgery

Literature

M. M. Souweidane, P. F. Morgenstern, S. Kang et al.

Endoscopic Third Ventriculostomy in Patients with a Diminished Prepontine Interval

Journal of Neurosurgery: Pediatrics, Vol. 5, 250-254, March 2010

O. Sacko, S. Boetto, V. Lauwers-Cances, et al.

Endoscopic Third Ventriculostomy: Outcome Analysis in 368 Procedures

Journal of Neurosurgery: Pediatrics, Vol. 5, 68-74, January 2010

N. Luther, W. R. Stetler Jr., Ira. J. Dunkel, et al.

Subarachnoid Dissemination of Intraventricular Tumors Following Simultaneous Endoscopic Biopsy and Third Ventriculostomy

Journal of Neurosurgery: Pediatrics, Vol. 5, 61-67, January 2010

G. P. Lekovic, J. F. Kerrigan, S. Wait, et al.

In Situ Single-Unit Recording of Hypothalamic Hamartomas Under Endoscopic Direct Visualization

Neurosurgery, Vol. 65, Nr. 6, E1195-E1196, December 2009

B. D. Kollroy, F. A. Ponce, Scott D. Wait, et al.

Endoscopic Intraventricular Biopsy of Infundibular Langerhans Cell Histiocytosis: Case Report

Neurosurgery, Vol. 65, Nr. 1, E214-E215, July 2009

P. Pillai, M. N. Baig, Ch. S. Karas, et al.

Endoscopic Image-Guided Transoral Approach to the Craniovertebral Junction: An Anatomic Study Comparing Surgical Exposure and Surgical Freedom Obtained with the Endoscope and the Operating Microscope

Neurosurgery, Operative Neurosurgery 2, Vol. 64, ONS437-ONS444, May 2009

N. J. Hopf, A. Stadie, R. Reisch, et al.

Surgical Management of Bilateral Middle Cerebral Artery Aneurysms via a Unilateral Supraorbital Key-Hole Craniotomy

Minimally Invasive Neurosurgery, Vol. 52, 126-131, 2009

R. Reisch, A. Stadie, R. Kockro, et al.

The Minimally Invasive Supraorbital Subfrontal Key-Hole Approach for Surgical Treatment of Temporomesial Lesions of the Dominant Hemisphere

Minimally Invasive Neurosurgery, Vol. 52, 163-169, 2009

J. Leonardo, R. A. Hanel, W. Grand

Endoscopic Tracking of a Ventricular Catheter for Entry into the Lateral Ventricle: Technical Note

Minimally Invasive Neurosurgery, Vol. 52, 287-289, 2009

A. T. Stadie, R. Reisch, R. A. Kockro, et al.

Minimally Invasive Cerebral Cavernoma Surgery Using Keyhole Approaches – Solutions for Technique-Related Limitations

Minimally Invasive Neurosurgery, Vol. 52, 9-16, 2009

P. Pillai, M. Lubow, A. Ortega, et al.

Endoscopic Transconjunctival Surgical Approach to the Optic Nerve and Medial Intraconal Space: A Cadaver Study

Neurosurgery, Operative Neurosurgery 2, Vol. 63, OBS204-ONS209, October 2008

S. C. Froelich, K. M. Abdel Aziz, P. D. Cohen, et al.

Microsurgical and Endoscopic Anatomy of Lilliequist's Membrane: A Complex and Variable Structure of the Basal Cisterns

Neurosurgery, Operative Neurosurgery 1, Vol. 63, ONS1-ONS9, July 2008

B. C. Ong, P. A. Gore, M. B. Donnellan, et al.

Endoscopic Sublabial Transmaxillary Approach to the Rostral Middle Fossa

Neurosurgery, Operative Neurosurgery 1, Vol. 62, 30-37, March 2008

J. D. W. Greenlee, C. Teo, A. Ghahreman, et al.

Purely Endoscopic Resection of Colloid Cysts

Neurosurgery, Operative Neurosurgery 1, Vol. 62, ONS51-ONS56, March 2008

P. A. Gore, L. F. Gonzalez, H. L. Rekate, et al.

Endoscopic Supracerebellar Infratentorial Approach for Pineal Cyst Resection: Technical Case Report

Neurosurgery, Operative Neurosurgery 1, Vol. 62, March 2008

P. Cappabianca, G. Cinalli, M. Gangemi, et al.

Application of Neuroendoscopy to Intraventricular Lesions

Neurosurgery, Supplement, Vol. 62, No. 2, SHC575-SHC598, February 2008

J. P. Greenfield, L. Z. Leng, U. Chaudhry, et al.

Combined Simultaneous Endoscopic Transsphenoidal and Endoscopic Transventricular Resection of a Giant Pituitary Macroadenoma

Minimally Invasive Neurosurgery, Vol. 51, 306-309, 2008

P. Y. Hwang, C. Long Ho

Neuronavigation Using an Image-Guided Endoscopic Transnasal-Sphenoethmoidal Approach to Clival Chordomas

Neurosurgery, Operative Neurosurgery 2, Vol. 61, ONS212-ONS218, November 2007

B. Depreitere, N. Dasi, J. Rutka, et al.

Endoscopic Biopsy for Intraventricular Tumors in Children

Journal of Neurosurgery: Pediatrics, Vol. 106, 340-346, May 2007

M. Gangemi, F. Maiuri, G. Colella, et al.

Is Endoscopic Third Ventriculostomy an Internal Shunt Alone?

Minimally Invasive Neurosurgery, Vol. 50, 47-50, 2007

M. Husain, M. Rastogi, B. K. Ojha, et al.

Endoscopic Transoral Surgery for Craniovertebral Junction Anomalies

Journal of Neurosurgery: Spine, Vol. 5, 367-373, October 2006

C. Teo, P. Nakaji, R. J. Mobbs

Endoscope-Assisted Microvascular Decompression for Trigeminal Neuralgia: Technical Case Report

Neurosurgery, Operative Neurosurgery 4, Vol. 59, October 2006

A. Weyerbrock, T. Mainprize, J. T. Rutka

Endoscopic Fenestration of a Symptomatic Cavum Septum Pellucidum: Technical Case Report

Neurosurgery, Operative Neurosurgery 4, Vol. 59, October 2006

R. Moftakhar, M. S. Salamat, S. Sahin, et al.

Endoscopically-Assisted Resection of a Choroid Plexus Vascular Malformation Traversing the Cerebral Aqueduct: Technical Case Report

Neurosurgery, Operative Neurosurgery 1, Vol. 59, July 2006

J. van Beijnum, P. W. Hanlo, K. Sen Han, et al.

Navigated Laser-Assisted Endoscopic Fenestration of a Suprasellar Arachnoid Cyst in a 2-Year-Old Child with Bobble-Head Doll Syndrome

Journal of Neurosurgery: Pediatrics, Vol. 104, 348-351, May 2006

Aesculap Neurosurgery

Literature

F. T. Mangano, D. D. Limbrick, J. R. Leonard, et al.

Simultaneous Image-Guided and Endoscopic Navigation without Rigid Cranial Fixation: Application in Infants: Technical Case Report

Neurosurgery, Operative Neurosurgery 2, Vol. 58, ONS-377-ONS-378, April 2006

G. P. Lekovic, L. F. Gonzalez, I. Feiz-Erfan, et al.

Endoscopic Resection of Hypothalamic Hamartoma using a Novel Variable Aspiration Tissue Resector

Neurosurgery, Operative Neurosurgery 1, vol. 58, ONS166-ONS169, February 2006

A. Morita, M. Shin, L. N. Sekhar, et al.

Endoscopic Microneurosurgery: Usefulness and Cost-Effectiveness in the Consecutive Experience of 210 Patients

Neurosurgery, Vol. 58, No. 2, 315-321, February 2006

A. A. Figaji, A. G. Fieggen, P. L. Semple, et al.

Intracranial Endoscopy

Samj Forum, Vol. 96, No. 1, 32-37, January 2006

A. Bussarsky, M. Marinov, V. Bussarsky, et al.

Virtual Simulation of Neuroendoscopic Procedures: Early Clinical Experience with Ventricular Lesions

Central European Neurosurgery, Vol. 67, 129-136, 2006

J. Zhao, Y. Wang, Y. Zhao, et al.

Neuroendoscope-Assisted Minimally Invasive Microsurgery for Clipping Intracranial Aneurysms

Minimally Invasive Neurosurgery, Vol. 49, 335-341, 2006

Y. Arakawa, K. Nakazawa, H. Kataoka, et al.

Microfiberscope Coaxial Technique in Neuroendoscopic Surgery

Minimally Invasive Neurosurgery, Vol. 49, 380-383, 2006

I. Gawish, R. Reisch, A. Perneczky

Endoscopic Aqueductoplasty through a Tailored Craniocervical Approach

Journal of Neurosurgery, Vol. 103, 778-782, November 2005

R. Reisch, A. Perneczky

Ten-Year Experience with the Supraorbital Subfrontal Approach through an Eyebrow Skin Incision

Neurosurgery, Operative Neurosurgery 4, Vol. 57, ONS242-ONS255, October 2005

M. M. Souweidane

Endoscopic Surgery for Intraventricular Brain Tumors in Patients without Hydrocephalus

Neurosurgery, Operative Neurosurgery 4, Vol. 57, ONS312-ONS318, October 2005

K. Schmidt, C. Coimbra

Endoscopic Treatment of Thalamic Neuroepithelial Cysts

Journal of Neurosurgery, Vol. 103, 342-346, August 2005

N. Luther, A. Cohen, M. M. Souweidane

Hemorrhagic Sequelae from Intracranial Neuroendoscopic Procedures for Intraventricular Tumors

Neurosurgical Focus, Vol. 19 (1), E9, 1-4, July 2005

P. D. Purdy, T. Fujimoto, R. E. Replogle, et al.

Percutaneous Intraspinal Navigation for Access to the Subarachnoid Space: Use of Another Natural Conduit for Neurosurgical Procedures

Neurosurgical Focus, Vol. 19 (1), E11, 1-5, July 2005

M. M. Souweidane

Endoscopic Management of Pediatric Brain Tumors

Neurosurgical Focus, Vol. 18 (6a), E1, June 2005

N. Luther, M. M. Souweidane

Neuroendoscopic Resection of Posterior Third Ventricular Ependymoma

Neurosurgical Focus, Vol. 18 (6a), E3, 1-2, June 2005

E. Nathal, J. L. Gomez-Amador

Anatomic and Surgical Basis of the Sphenoid Ridge Keyhole Approach for Cerebral Aneurysms

Neurosurgery, Operative Neurosurgery 1, Vol. 56, ONS178-ONS185, January 2005

J. Martin, C. Neal, I. Moores, et al.

Use of a Nitrogen Arm-Stabilized Endoscopic Microdriver in Neuroendoscopic Surgery

Minimally Invasive Neurosurgery, Vol. 48, 63-65, 2005

M.J. Fritsch, L. Dörner, S. Kienke, et al.

Hydrocephalus in children with posterior fossa tumors: The role of Endoscopic Third Ventriculostomy (ETV)

Journal of Neurosurgery: Pediatrics, Vol. 103: 40-42, 2005

M.J. Fritsch, S. Kienke, T. Ankermann, et al.

Endoscopic Third Ventriculostomy (ETV) in infants

Journal of Neurosurgery: Pediatrics, Vol. 103: 50-53, 2005

M. Taniguchi, A. Kato, T. Taki, et al.

Endoscope Assisted Removal of Jugular Foramen Schwannoma; Report of 3 Cases

Minimally Invasive Neurosurgery, Vol. 48, 365-368, 2005

H. Kinouchi, T. Yanagisawa, A. Suzuki, et al.

Simultaneous Microscopic and Endoscopic Monitoring During Surgery for Internal Carotid Artery Aneurysms

Journal of Neurosurgery, Vol. 101, 989-995, December 2004

J. C. Wang, L. Heier, M. M. Souweidane

Advances in the Endoscopic Management of Suprasellar Arachnoid Cysts in Children

Journal of Neurosurgery: Pediatrics, Vol. 100, 418-426, May 2004

M.J. Fritsch, S. Kienke, H.M. Mehdorn

Endoscopic aqueductoplasty: stent or not to stent?

Childs Nerv System, Vol. 20, 137-142, 2004

M.J. Fritsch, K.H. Manwaring, S. Kienke, et al.

Endoscopic treatment of isolated 4th ventricle in children

Neurosurgery, Vol. 55, 372-379, 2004

C. Trantakis, J. Helm, M. Keller, et al.

Third Ventriculostomy in Communicating Hydrocephalus in Adult Patients – The Role of Lumbar and Cranial Cerebrospinal Fluid Outflow Measurement

Minimally Invasive Neurosurgery, Vol. 48, 140-144, 2004

Aesculap Neurosurgery

Literature

S. Wolfsberger, M.-T. Forster, M. Donat, et al.

Virtual Endoscopy is a Useful Device for Training and Preoperative Planning of Transsphenoidal Endoscopic Pituitary Surgery

Minimally Invasive Neurosurgery, Vol. 47, 214-220, 2004

Y. Lin, Y. Qiu

Microanatomy of Endoscope-Assisted Glabellar Nasal Keyhole Approach

Minimally Invasive Neurosurgery, Vol. 46, 155-160, 2003

T. G. Psarros, J. Krumerman, C. Coimbra

Endoscopic Management of Supratentorial Ventricular Neurocysticercosis: Case Series and Review of the Literature

Minimally Invasive Neurosurgery, Vol. 46, 331-334, 2003

M. A. Barajas, G. Ramirez-Guzmán, C. Rodríguez-Vazquez, et al.

Multimodal Management of Craniopharyngiomas: Neuroendoscopy, Microsurgery, and Radiosurgery

Journal of Neurosurgery (Supplement 5), Vol. 97, 607-609, December 2002

Z. Horváth, F. Vető, I. Balás, et al.

Biportal Endoscopic Removal of a Primary Intraventricular Hematoma: Case Report

Minimally Invasive Neurosurgery, Vol. 43, 4-8, 2000

A. Rieger, N. G. Rainov, M. Brucke, et al.

Endoscopic Third Ventriculostomy is the Treatment of Choice for Obstructive Hydrocephalus due to Pediatric Tumors

Minimally Invasive Neurosurgery, Vol. 43, 83-86, 2000

V. Rohde, J. M. Gilsbach

Anomalies and Variants of the Endoscopic Anatomy for Third Ventriculostomy

Minimally Invasive Neurosurgery, Vol. 43, 111-117, 2000

J. Paladino K. Rotim, D. Štimac, et al.

Endoscopic Third Ventriculostomy with Ultrasonic Contact Microprobe

Minimally Invasive Neurosurgery, Vol. 43, 132-134, 2000

T. Menovsky, J. A. Grotenhuis, J. de Vries, et al.

Endoscope-Assisted Supraorbital Craniotomy for Lesions of the Interpeduncular Fossa Technique and Application

Neurosurgery, Vol. 44, No. 1, 106-112, January 1999

P. Wieneke, T. Lutze

Technologies for Microendoscopes of the Future: The MINOP Project

Minimally Invasive Therapy & Allied Technology, Vol. 7/3, 233-239, 1998

E. van Lindert, N. Hopf, A. Perneczky

Endoscopic Treatment of Mesencephalic Ependymal Cysts: Technical Case Report

Neurosurgery, Vol. 43, No. 5, November 1998

F. Vető, Z. Horváth, T. Dóczi

Biportal Endoscopic Management of Third Ventricle Tumors in Patients with Occlusive Hydrocephalus: Technical Note

Neurosurgery, Vol. 40, No. 4, 871-877, April 1997

J. A. Grotenhuis

Endoscope-Assisted Craniotomy

Techniques in Neurosurgery, Vol. 1, No. 3, 201-212, 1996

G. Fries, R. Reisch

Biportal Neuroendoscopic Microsurgical Approaches to the Subarachnoid Cisterns: A Cadaver Study

Minimally Invasive Neurosurgery, Vol. 39, 99-104, 1996

A. Perneczky

Planning Strategies for the Suprasellar Region

Neurosurgeons 11, 343-348, 1992

Aesculap Neurosurgery

Numerical Index

BN175R	89	FA065R	61	FD731B	50
		FA065R	73	FD732B	50
EJ751200	19	FA066R	61	FD733B	50
EJ751251	19	FA066R	73	FD734B	50
		FA067R	61	FD735B	50
FA030R	74	FA067R	73	FD736B	50
FA031R	74	FA068R	61	FD741B	52
FA032R	74	FA068R	73	FD743B	52
FA033R	74	FA069R	85	FD761B	52
FA034R	74	FA070R	85	FD763B	52
FA035R	74	FA071R	85	FD766B	53
FA036R	74	FA072R	84	FD767B	53
FA037R	74	FA073R	84	FD768B	53
FA038R	74	FA074R	84	FD769B	53
FA039R	74	FA075R	84	FD771B	50
FA040R	74	FA076R	78	FD772B	50
FA041R	60	FD113D	62	FD773B	50
FA041R	72	FD114D	62	FD774B	50
FA042R	60	FD115D	62	FD775B	50
FA042R	72	FD116D	62	FD776B	50
FA043R	60	FD137R	75	FD786B	53
FA043R	72	FD138R	75	FD787B	53
FA044R	60	FD139R	75	FD788B	53
FA044R	72	FD220R	83	FD789B	53
FA045R	60	FD222R	83	FD797B	54
FA045R	72	FD224R	83	FD798B	54
FA046R	60	FD226R	83	FD799B	54
FA046R	72	FD228R	82	FD805B	54
FA047R	60	FD228R	83	FD808B	54
FA047R	72	FD467R	55	FD809B	54
FA060R	60	FD701B	50	FD811B	54
FA060R	72	FD702B	50	FD812B	54
FA061R	61	FD703B	50	FD814B	54
FA061R	73	FD704B	50	FD815B	54
FA062R	61	FD705B	50	FD816B	54
FA062R	73	FD706B	50	FD821B	54
FA063R	61	FD711B	52	FD822B	54
FA063R	73	FD717B	51	FD823B	54
FA064R	61	FD718B	51	FD824B	55
FA064R	73	FD719B	51	FD825B	55

FD826B	55	FF432R	13	FH624R	29
FD827B	55	FF433R	13	FH625R	29
FD828B	55	FF435R	13	FH626R	29
FD831B	55	FF435R	31	FH627R	29
FD832B	55	FF436R	13	FH628R	29
FD833B	55	FF436R	31	FH629R	28
FD835B	55	FF437R	13	FH630R	28
FD836B	55	FF437R	31	FH631R	28
FD839B	55	FF438R	13	FH632R	28
FD840B	55	FF438R	31	FH633R	31
FD841B	55	FF439R	13	FH634R	28
FE490K	48	FF439R	31	FH635200	31
FE491K	48	FF456B	63	FH635R	30
FE495K	48	FF457B	63	FH636R	30
FE496K	48	FF458B	63	FH637R	30
FF151R	92	FF459B	63	FH638R	30
FF168R	92	FF496R	65	FH639R	30
FF280R	92	FF496R	91	FK900B	64
FF345R	80	FF497R	65	FK901B	64
FF357R	70	FF497R	91	FK902B	64
FF358R	18	FF498R	65	FK906B	90
FF359R	18	FF498R	91	FK906R	90
FF373R	14	FF499R	65	FK907B	90
FF373R	21	FF499R	91	FK907R	90
FF373R	34	FH358R	35	FK908B	90
FF374R	14	FH359R	35	FK908R	90
FF374R	21	FH603SU	21	FK909B	90
FF374R	34	FH604SU	17	FK909R	90
FF378R	14	FH605SU	70	FK911B	64
FF378R	21	FH606SU	16	FK912B	64
FF378R	34	FH606SU	34	FK913B	64
FF379R	23	FH607SU	16	FK914B	64
FF385R	12	FH607SU	34	FK923B	90
FF386R	12	FH610R	71	FK923R	90
FF387R	12	FH611R	71	FK924B	90
FF388R	12	FH615	70	FK924R	90
FF389R	12	FH620R	26	FK936R	90
FF397R	9	FH621R	29	FK937R	90
FF398R	9	FH622R	29	FK938R	90
FF399R	8	FH623R	29	FK966B	64

Aesculap Neurosurgery

Numerical Index

FK967B	64	FM730R	44	GB756R	106
FM156R	89	FM730R	45	GB757R	106
FM157R	89	FM730R	46	GB758R	106
FM158R	89	FM730R	47	GB761SU	114
FM670R	44	FM731R	44	GB762SU	114
FM671R	44	FM731R	45	GB763SU	114
FM672R	44	FM731R	46	GB764SU	114
FM675R	44	FM731R	47	GB767SU	114
FM676R	44	FM732R	44	GB771R	110
FM677R	44	FM732R	45	GB790R	112
FM680R	45	FM732R	46	GB791R	112
FM681R	45	FM732R	47	GB792R	112
FM682R	45	FT490T	48	GB793R	112
FM685R	45	FT491T	48	GB794R	112
FM686R	45	FT495T	48	GB796SU	114
FM687R	45	FT496T	48	GB797SU	114
FM690R	44			GD668	102
FM691R	44	GA461R	103	GD670	102
FM692R	44	GA464R	103	GD672	102
FM695R	44	GA468R	103	GD675	102
FM696R	44	GA513R	103	GD685	102
FM697R	44	GA521	103	GE381R	105
FM700R	45	GA740R	103	GE382R	105
FM701R	45	GA742R	103	GE382R	105
FM702R	45	GB600	114	GE386SU	105
FM705R	45	GB600820	114	GE387SU	105
FM706R	45	GB600870	114	GE389R	105
FM707R	45	GB740R	104	GE390R	105
FM710R	47	GB740R	114	GE391R	105
FM711R	47	GB741R	104	GE392R	105
FM712R	47	GB742R	104	GE394R	105
FM715R	47	GB743R	104	GE395R	105
FM716R	47	GB744R	104	GE396R	105
FM717R	47	GB745R	104	GE397R	105
FM721R	46	GB746R	105	GE398R	105
FM722R	46	GB747R	105	GE399R	105
FM725R	46	GB748R	105	GE401R	107
FM725R	46	GB751R	106	GE402R	107
FM726R	46	GB752R	106	GE403R	107
FM727R	46	GB753R	106	GE404R	107

GE405R	107	GE504R	107	GE556SU	108
GE406R	107	GE505R	107	GE557SU	108
GE406TC-SU	109	GE506R	107	GE558SU	108
GE407R	107	GE507R	107	GE562R	108
GE407TC-SU	109	GE507TC-SU	109	GE563R	108
GE408R	107	GE508R	107	GE572R	107
GE408TC-SU	109	GE508TC-SU	109	GE573R	107
GE409R	107	GE509R	107	GE574R	107
GE411R	107	GE511R	107	GE603R	107
GE412R	107	GE512R	107	GE604R	107
GE413R	107	GE513R	107	GE605R	107
GE414R	107	GE514R	107	GE606R	107
GE415R	107	GE515R	107	GE607R	107
GE416R	107	GE516R	107	GE607TC-SU	109
GE417R	107	GE517R	107	GE608R	107
GE418R	107	GE518R	107	GE608TC-SU	109
GE419R	107	GE519R	107	GE609R	107
GE420R	105	GE520R	105	GE613R	107
GE424R	108	GE521R	108	GE614R	107
GE425R	108	GE522R	108	GE615R	107
GE429SU	105	GE523R	108	GE616R	107
GE435R	108	GE524R	108	GE617R	107
GE435TC-SU	109	GE525R	108	GE618R	107
GE437R	108	GE529SU	105	GE619R	107
GE456SU	108	GE531R	108	GE620R	105
GE457SU	108	GE534R	108	GE624R	108
GE459SU	108	GE535R	108	GE625R	108
GE460SU	108	GE535TC-SU	109	GE629SU	105
GE461SU	108	GE536R	109	GE631R	108
GE463SU	108	GE537R	108	GE634R	108
GE464SU	108	GE539R	109	GE635R	108
GE465SU	108	GE540R	109	GE635TC-SU	109
GE469SU	107	GE542R	109	GE639R	109
GE470SU	107	GE544R	109	GE644R	109
GE471SU	107	GE546R	109	GE645R	109
GE473SU	107	GE548R	109	GE646R	109
GE475SU	107	GE549R	109	GE648R	109
GE501R	107	GE550R	109	GE649R	109
GE502R	107	GE553R	108	GE650R	109
GE503R	107	GE555R	108	GE653R	108

Aesculap Neurosurgery

Numerical Index

GE654R	108	GE847SU	113	GF255R	87
GE655R	108	GE848SU	113	GF256R	87
GE656SU	108	GF005B	58	GF257R	87
GE657SU	108	GF025B	58	GF258R	87
GE658SU	108	GF026B	58	GF260R	87
GE700SU	110	GF027B	58	GF261R	87
GE702R	110	GF030B	58	GF262R	87
GE704R	110	GF031B	58	GF263R	87
GE706R	110	GF032B	58	GF264R	87
GE707R	110	GF033B	58	GF265R	87
GE708R	110	GF035B	58	GF266R	87
GE709R	110	GF036B	58	GF267R	87
GE711R	110	GF037B	58	GF268R	87
GE712R	110	GF038B	58	GF270R	87
GE714R	110	GF039B	58	GF271R	87
GE716R	110	GF045B	58	GF272R	87
GE717R	110	GF046B	58	GF273R	87
GE718R	110	GF047B	58	GF274R	87
GE719R	110	GF048B	58	GF275R	87
GE729R	110	GF049B	58	GF276R	87
GE802SU	113	GF055B	58	GF277R	87
GE803SU	113	GF056B	58	GF278R	87
GE804SU	113	GF057B	58	GF431R	86
GE805SU	113	GF058B	58	GF432R	86
GE812SU	113	GF059B	58	GF470R	59
GE813SU	113	GF235R	87	GF471R	59
GE814SU	113	GF240R	87	GF472R	59
GE815SU	113	GF241R	87	GF473R	59
GE816SU	113	GF242R	87	GF474R	59
GE817SU	113	GF243R	87	GF475R	59
GE818SU	113	GF244R	87	GF476R	59
GE832SU	113	GF245R	87	GF477R	59
GE833SU	113	GF246R	87	GF478R	59
GE834SU	113	GF247R	87	GF479R	59
GE835SU	113	GF248R	87	GF480R	59
GE842SU	113	GF250R	87	GF481R	59
GE843SU	113	GF251R	87	GK343R	32
GE844SU	113	GF252R	87	GK344R	32
GE845SU	113	GF253R	87	GK345R	32
GE846SU	113	GF254R	87	GK360R	15

GK360R	32	JK440	23	OK607R	78
GK361R	15	JK440	35	OK608R	78
GK361R	22	JK444	18	OK609R	78
GK361R	33	JK444	35	OK680R	79
GK362R	15	JK486	18	OK681R	79
GK362R	33	JK486	23	OK682R	79
GK363R	15	JK486	35	OK683R	79
GK363R	22	JK740	70	OK684R	79
GK363R	33	JK789	70	OP923	101
GK364R	15			OP930	100
GK364R	33	OF601R	89	OP940	101
GK365R	15	OK081R	77		
GK365R	33	OK082R	77	PE184A	10
GK366R	15	OK083R	77	PE204A	10
GK366R	33	OK084R	77	PE204A	27
GK560R	88	OK090R	76	PE486A	40
GK580R	88	OK090R	76	PE487A	71
GK777R	57	OK091R	77	PE506A	41
GK780R	57	OK092R	77	PE507A	71
GK781R	57	OK093R	77	PE526A	41
GK800R	88	OK094R	77	PF010A	20
GK801R	88	OK105R	76	PF011A	20
GK822R	56	OK106R	76	PF893800	19
GK823R	56	OK107R	76	PV460	100
GK824R	56	OK108R	76	PV462	100
GK825R	56	OK505R	81	PV463	100
GK826R	56	OK506R	81	PV470	101
GK827R	56	OK507R	81	PV472	101
GK828R	56	OK508R	81	PV473	101
GK829R	56	OK509R	81	PV840	100
GN130	15	OK520R	81	PV880	100
GN130	32	OK521R	81	PV880	101
GN202	15	OK522R	81	PV881	100
GN202	22	OK525R	80	PV881	101
GN202	33	OK560R	82	PV884	100
		OK561R	82	PV884	101
JF324R	41	OK562R	82	PV909	100
JG901	93	OK602R	78	PV909	101
JG904	100	OK603R	78	PV956	100
JK440	18	OK606R	78	PV959	101

Aesculap Neurosurgery

Numerical Index

RT020R	93
RT040R	93
RT043R	93
RT044SU	93
RT046P	94
RT046P	95
RT055P	94
RT060R	97
RT060R	98
RT061R	97
RT061R	98
RT063P	98
RT063R	97
RT064P	98
RT064R	97
RT065P	98
RT065R	97
RT066P	98
RT066R	97
RT068R	94
RT068R	95
RT079205	94
RT079R	94
RT079R	95
RT081R	94
RT090R	92
RT099R	70
RT099R	94
RT099R	95

